



Enclosures Solutions Product Catalog 2004

Rack Cabinets
Rack Accessories
Rackmount Kits
Testmobile Carts



Agilent Technologies

Table of Contents

Introduction	
How to Use the Agilent Enclosure Catalog	3
Ordering Guide	4

One Rack Cabinets

Features	5
Standard Rack Cabinets	7
Specifications	8
Rack Cabinet with Factory-installed Power Distribution Units	9
Multi-bay Rackmount Configurations	12
Configuration Guide	12
Tie Kits	12

Two Rack Accessories

Power Distribution Units	12
Front Doors	14
Rear Doors	15
Extractor Fans	17
Drawers	18
Shelves	19
Work Surface	20
Ballast	21

Three Rackmount Kits

Monitor Rackmount Kits	22
Keyboard Rackmount Kits	23
Instrument Rackmount Kits	25
Instrument Compatibility with Racks	25
Handles & Rackmount Flanges	26
Rackmount Adapter Kits	29
Support Shelf, Filler Panels & Slides	30
Lock Link Kits	32
Rail Kits	33
Slide Kits	34
End Brackets	34

Four Small Parts

Feedthrough Panels	35
Rack Filler Panels	36
Power Cables	36
Mounting Hardware	37
Leveling Screws	38
Rackmount Caster	38
Rear Door Hinge	38
Forehead Bezels	38
Quartz Gray Paint	38

Five Testmobiles & Accessories

Features	39
Scope Cart	40
System Cart	41
Specifications	42
Accessories	42
Printer/Plotter Stand	42
Work Surface	43
Storage Drawer	44
Stationary Shelf	44
Power Cables	45

How to use the Agilent Enclosure Catalog

This catalog has been standardized to help you navigate the pages more easily. Every product page in the catalog includes common features to help you quickly and easily identify the information you are seeking.

- 1) Product category
- 2) Product and description: Each product page will begin with a general description of the product and its role in the rack system.
- 3) Specifications: The specifications box details the key dimensions of the product, including weight and load capacity.
- 4) Photographed detail of product: A photograph of the product will help you visualize how that piece fits into your system.
- 5) Dimensional schemes
- 6) Shipping contents: A list of the essential materials that are shipped with products will be listed. This is a condensed bill of materials (BOM).
- 7) Ordering information: This section details specific features you need to know when placing the order. This includes order number and any important product-specific features.
- 8) Must read box: Many products have important information that you should note. For these products, we have included a "Must Read" orange box that contains this important information.

Rack Accessories

1 Product category

2 Product

▶ Drawers

Mount a drawer in the rack to keep manuals or spare cables close to where they are needed. Two drawer sizes are available. Sliding rails and mounting hardware are included.

6 Shipping contents

What you get in the box
Drawer with slides attached
Mounting hardware

4 Photographed detail of product



Drawer installed

5 Dimensions diagram

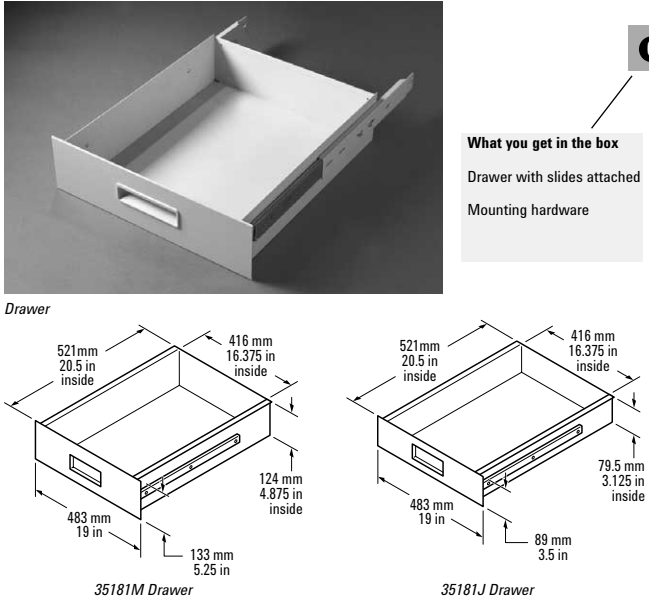

Drawer

35181M Drawer

35181J Drawer

3 Part Specifications

	35181J	35181M
Material	Cold-rolled steel	Cold-rolled steel
Weight	7.26 kg (16 lbs)	8.16 kg (18 lbs)
Color	Quartz gray	Quartz gray
Length	521 mm (20.5 in)	521 mm (20.5 in)
Height	89 mm (3.5 in)	133 mm (5.25 in)
Width	483 mm (19 in)	483 mm (19 in)

7 Order details

Part No.	Description	Height Dimensions	EIA Units
35181J	Storage drawer, 3.5"	89 mm (3.5 in)	2
35181M	Storage drawer, 5.25"	133 mm (5.25 in)	3

8 Must read box

Must Read Box
Sample must read box

One Rack Cabinets

Rack Solution for Agilent Systems

Agilent Technologies offers 19-inch EIA (Electronics Industries Association) rack cabinets tailored to meet the needs of test and measurement instrumentation customers. Rack mounting is fast and easy with unique design features. A selection of options and accessories provides flexibility to meet the vast majority of racking applications.



Standard rack cabinet (E3661B)

Standard Rack Includes:

- Vented top for better cooling
- Solid base
- Leveling screws
- Retractable anti-tip foot
- 4 Concealed lifting hooks. Each hook can support 227 kg (500 lbs).
- One Agilent System II rail kit, including a pair of rails.
- 3-Inch heavy duty casters
- Power distribution Unit (PDU) – must specify 110v or 220v
- Vented, swinging rear door with lock
- Easy to remove side panels, which can be lifted off
- Attractive quartz gray color



Standard rack cabinets: E3661B (32 EIA), E7590A (25 EIA), E3662B (41 EIA)

Shipping Features

All racks and accessories are shipped with basic assembly completed, as shown.

Agilent Rack Value

Agilent racks have been designed and engineered to save time and money for our customers:

- Package design — Designed for easy unloading from the pallet.
- Pallet re-use — Racks are sent out with double pallets, as well as a ramp. Racks can be integrated on the pallet, which adds a convenient system for integrating the rack. The pallet has been tested up to 1000 pounds and can be used to ship an integrated system, saving you time and money.
- Fully assembled rack — Customers receive Agilent racks fully assembled and ready for equipment installation saving time and money. Accessories

can be ordered, and will be shipped ready to be integrated onto the rack.

- Unique column and rail design — Equipment installation time is cut in half because of Agilent's unique column and support rail design. Our special cutouts in the columns, spaced at EIA intervals and rail hooks assure instruments are mounted easily in the right place the first time!

Enhance Your Instrument Investment

Agilent racks are specifically designed for Agilent's test and measurement equipment, virtually ensuring a perfect fit. Agilent racks will also accommodate non-Agilent equipment making them suitable for the customer of a mixed instrument environment. Designed for today's competitive environment, three heights are offered to accommodate any system: 1.3 m, 1.6 m, and 2.0 m. All racks

Rack Cabinets

are deep enough to hold Agilent instruments of varying sizes.

Load a Rack in Less Time

The design of Agilent support rails can cut in half the time required to install equipment in a rack. The rails hang on discrete slots on the vertical mounting columns, corresponding to each EIA unit in the rack. Vertical adjustment between instruments is minimized by selecting the proper rail. Rails are available for Agilent System II instruments and for flat bottom instrument chassis (see page 34). The system was specifically designed to minimize the time required to install instruments.

Rack Systems Fast and Easily

Racks are shipped with all basic materials assembled. No time is lost preparing a rack with basic assembly. Accessories, kits and supplementary small parts are shipped

separately, as ordered, and are ready for immediate configuration.

More than just a way of storing instruments, the racks reflect Agilent's reputation for quality and design. A sturdy frame provides structural integrity, which allows lightweight, easy-to-lift off side panels that allow for installation and easy access to equipment and cables. Rails are placed into keyed slots in the vertical columns, resulting in quick and accurate positioning.

Use Vertical Space Efficiently

Vertical space within a rack is measured in industry-standard EIA units, where 1 EIA unit = 1.75 inches (44.5 mm). Equipment height is also specified in EIA units. System configuration is made easier by counting EIA units from the base of the rack. A seamless fit of instrument and rail is ensured.

Manage Power Requirements

A power management system must be ordered. Option AW3 (110v) or option

AW5 (220v). It is vertically mounted behind the rack rear column and supplies power to the cabinet. An illuminated master switch, which is conveniently located on the front of the rack, provides easy access to turn the power on and off.

Protect from Heat Buildup

It is important for racks to efficiently dispose of heat. Instruments increasingly generate more heat, and in a compact rackmounted system the heat buildup can be detrimental to the system.

System-generated heat is removed by natural convection through a ventilation path incorporated in the roof of the racks. The vented rear door also helps reduce the heat captured within the rack. For greater heat dissipation, an optional easy to install top-mounted extractor fan is available. (see page 17)

Secure Instruments During Test

Both the rear door and the optional Plexiglas front door can be locked to secure against disruption of tests or unauthorized removal of system components. The symmetrical rear door design allows it to be mounted for opening to either left or right, useful for multi-bay configurations.

Move Racks Easily

Each rack is provided with four 3-inch diameter, smooth-rolling, heavy-duty casters to facilitate moving racks over short distances. Four lifting hooks conveniently concealed in the top of the rack allow for transport, even when fully loaded. Each hook can support 227 kg (500 lbs) to easily handle the maximum

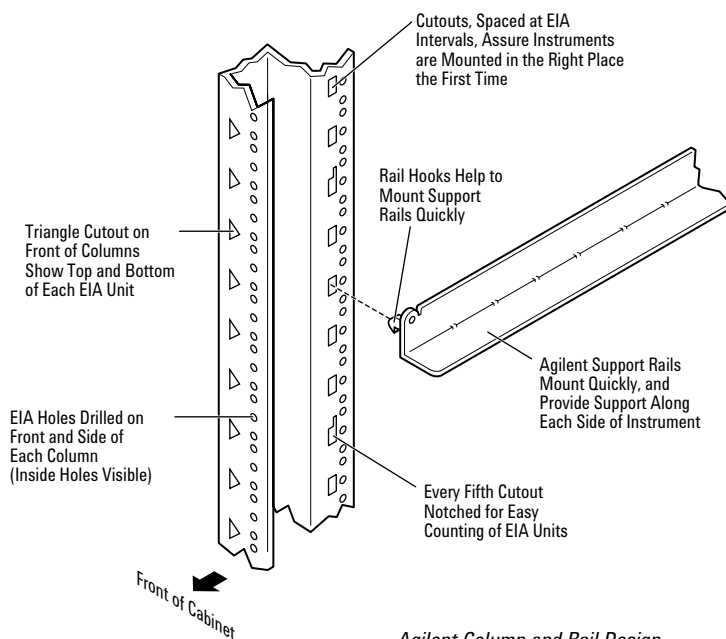

Agilent Column and Rail Design

Rack Cabinets

recommended gross weight for a loaded rack of 816 kg (1800 lbs).

Enhance Stability

A front mounted retractable anti-tip stabilizer that can be extended into place with ease is standard on all racks. It provides temporary anti-tip capability for slide mounted products when they are in their extended position. Use the optional anti-tip ballast kit when permanent anti-tip capability is desired.

Improve Cable Management

Agilent racks, including the 1.3 m, 1.6 m and 2.0 m, have an additional 100 mm of

internal space that is available at the rear of the rack. This convenient space is available for the installation of power distribution units (PDUs) and as a convenient location for cables, which are routed out the bottom of the rack. The added rear space also enhances air flow.

Ventilation

Agilent standard racks include a vented top cap and 100 mm additional internal rear space enhancing air flow.

Material

Frame/columns: 13 Ga. cold rolled steel.
Side Panels: 18 Ga. cold rolled steel.

▼ Standard Rack Cabinets — 1.3 m, 1.6 m, 2.0 m

Our line of rack cabinets will optimize your storage ability for your instruments.

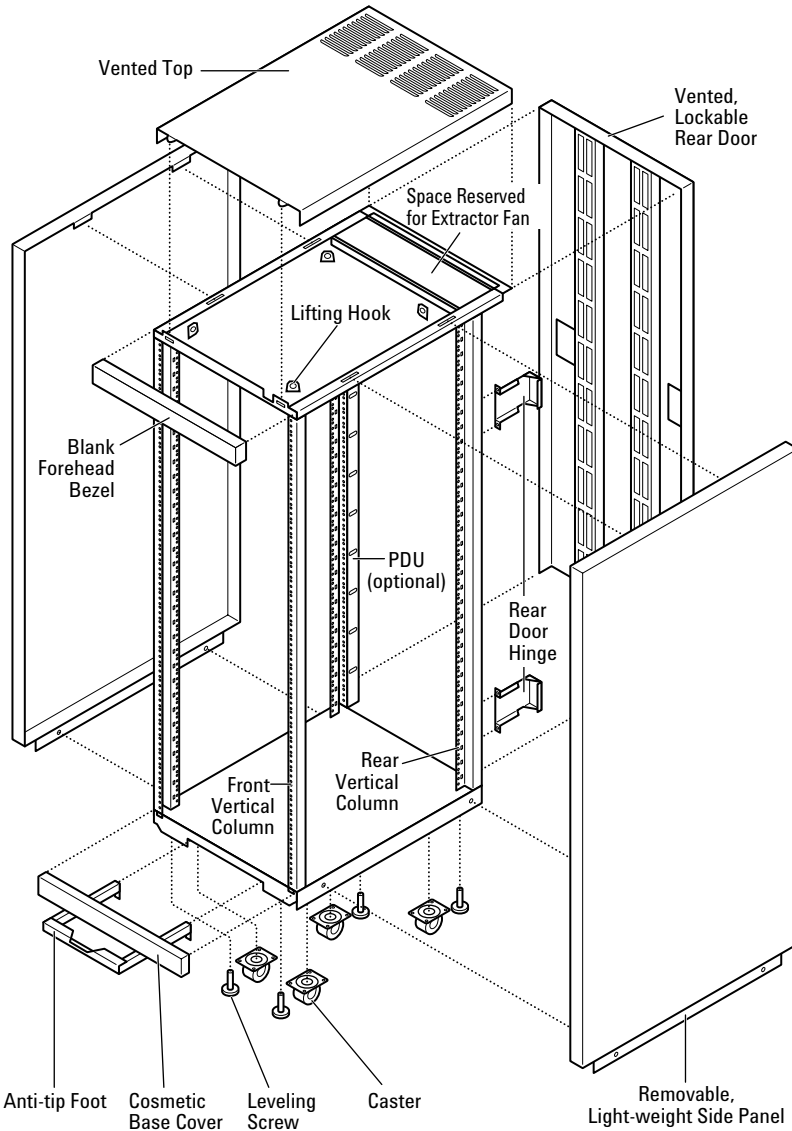

Exploded View of Standard Rack

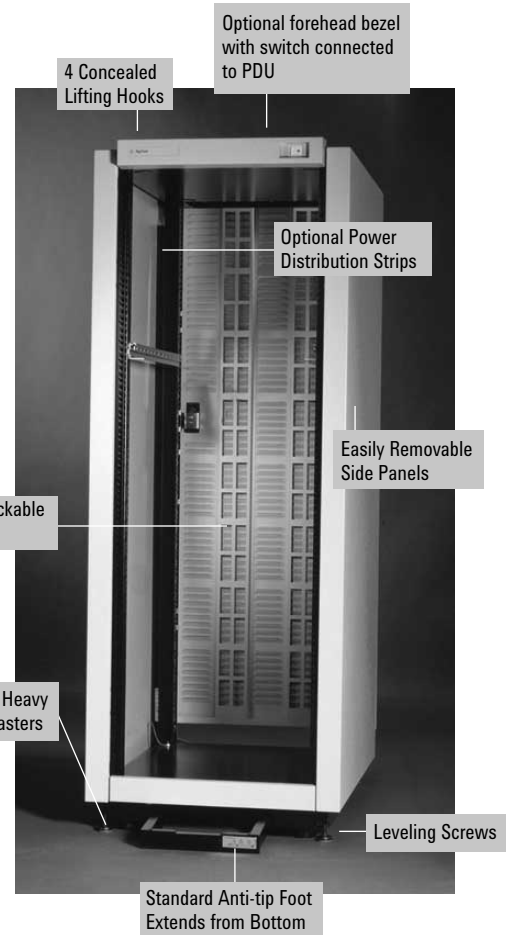

What you get in the box

- Rack cabinet (fully assembled) with vented top cover & bezel
- Leveling screws
- Retractable anti-tip foot
- One system II rail kit (pair of Agilent rails)
- 4 integral concealed lifting hooks.
- 4 3-inch heavy duty casters
- Factory integrated (to your order) with vented, lockable rear door
- 2 removable side panels
- Power distribution unit & bezel with switch
- Re-usable integration pallet

Rack Cabinets

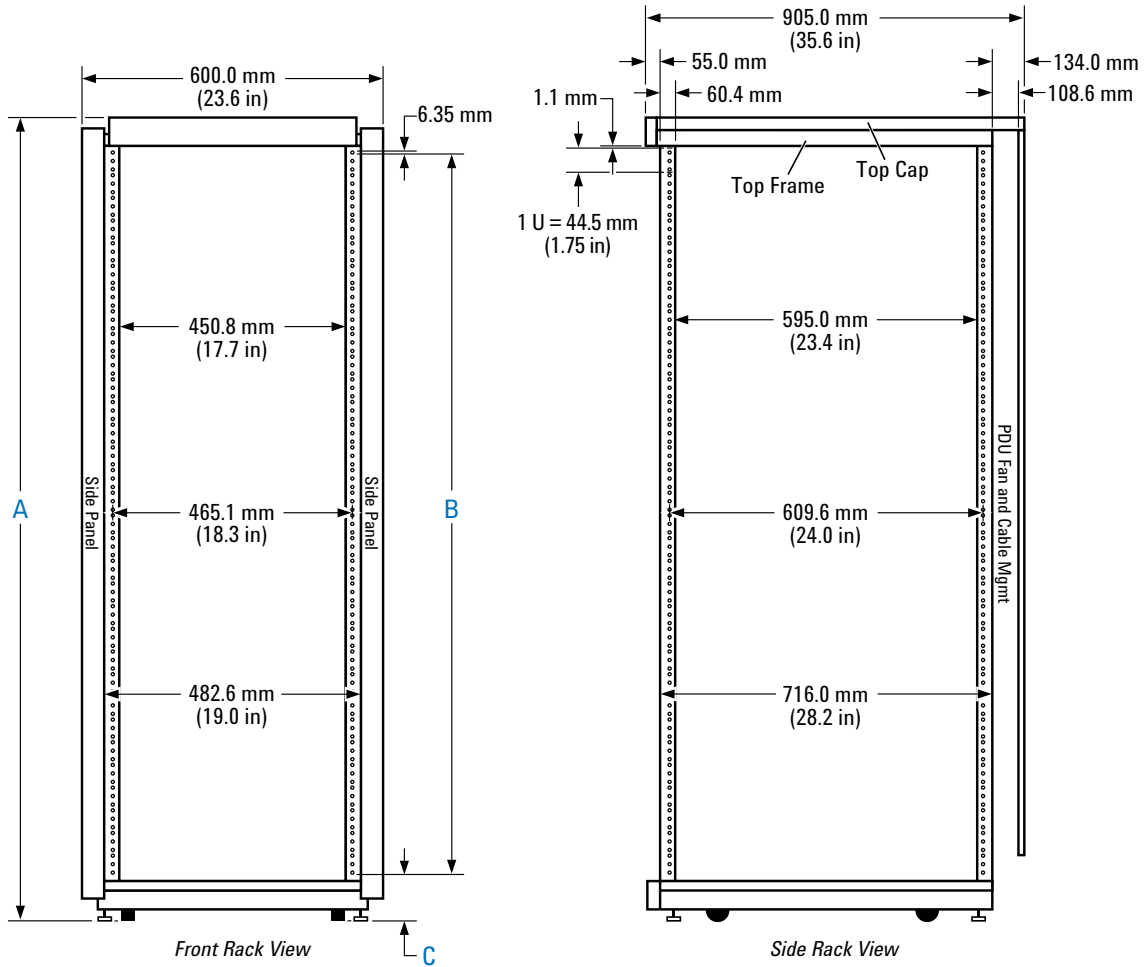

E7590A	E3661B	E3662B
A 1320 mm (51.9 in)	A 1620 mm (63.8 in)	A 2020 mm (79.5 in)
B 1111.3 mm (43.8 in)	B 1422.4 mm (56.0 in)	B 1822.5 mm (71.8 in)
C 120.8 mm (4.8 in)	C 131.8 mm (5.2)	C 131.8 mm (5.2 in)

Rack Specifications

Casters Rating	318 kg (700 lbs) each, 816 kg (1800 lbs) total Casters have a point contact convex cross section
Lift Hook Rating	227 kg (500 lbs) each Total system and cabinet weight is a maximum 816 kg (1800 lbs), static. Lift cabinet using all four (4) hooks.

Ordering Information

Prod. No.	Description	EIA Units
E7590A	1.3 m rack	25
E3661B	1.6 m rack	32
E3662B	2.0 m rack	41

Rack Dimensions, Weight and Load Ratings

Prod. No.		Dim	Height	Width	Depth	Weight	Load capacity	EIA Units
E7590A	Exterior	A	1320 mm (51.9 in)	600 mm (23.6 in)	905 mm (35.6 in)	89 kg (196 lbs) empty	816 kg (1800 lbs)	25
	Interior*	B	1111.25 mm (43.8 in)	450.8 mm (17.8 in)	851 mm (33.5 in)			
E3661B	Exterior	A	1620 mm (63.8 in)	600 mm (23.6 in)	905 mm (35.6 in)	100 kg (221 lbs) empty	816 kg (1800 lbs)	32
	Interior*	B	1422.5 mm (56.0 in)	450.8 mm (17.8 in)	851 mm (33.5 in)			
E3662B	Exterior	A	2020 mm (79.5 in)	600 mm (23.6 in)	905 mm (35.6 in)	116 kg (255 lbs) empty	816 kg (1800 lbs)	41
	Interior*	B	1822.5 mm (71.8 in)	450.8 mm (17.8 in)	851 mm (33.5 in)			

*Interior = EIA units = Rackmountable space.

Front to rear column hole spacing: 610 mm (24 in)

Rack Cabinets

► 1.3 m Rack Cabinet E7590A

E7590A Configurations

Solid side panels and a lockable vented rear door are standard equipment on the Agilent E7590A (1.3 m, 25 EIA Units) rack cabinet. To provide better value and save integration time, choose a variety of power distribution unit (PDU) options. Choose the PDU option you want, and your rack will arrive fully assembled and ready for use.

Power Distribution Unit (PDU) Options:

Factory installed PDUs are available in a 100-120V North American configuration (AW3) or a 200-240V International configuration (AW5). See the table below for descriptions and ordering information.

PDUs mount vertically behind the rear column and do not reduce the mounting space in the rack. Factory installation includes the specified PDU and a lighted, low-voltage safety power switch mounted in the rack's forehead bezel.

You can add a second PDU easily at a later date. See Page 13 for details.



Rack with PDU and switch

What you get in the box

- Rack cabinet (assembled with vented, lockable rear door,
- 2 removable side panels, vented top, solid base)
- Leveling screws
- Retractable anti-tip foot
- 4 3-inch heavy duty casters
- One System II rail kit (one set of Agilent instrument rails)
- Factory installed PDU (110V option AW3 or 220V option AW5)
- Forehead bezel with lighted safety switch

Must Read Box

Racks must specify a PDU Option: (AW3 or AW5)



IEC 320 C13



NEMA 5-15R



5-20 P non-locking

Factory Installed PDU Option Description

PDUs include: Forehead bezel with lighted switch, dual circuit breakers, IEC-320 upper receptacle for fan or other use.

North American PDU 100-120V, 16A

1 IEC-320 C-13 and 5 NEMA 5-15R Receptacles
2m cord with 5-20P non-locking plug
(To add a 2nd PDU by yourself, order accessory E4451AZ)

International PDU 200-240V, 16A

6 IEC-320 C-13 Receptacles
2m cord with no plug, user installs local plug
(To add a 2nd PDU by yourself, order accessory E4453AZ)

E7590A

1.3m
25 EIA

E7590A +
Option AW3

E7590A +
Option AW5

Rack Cabinets

► 1.6 m and 2.0 m Rack Cabinets E3661B and E3662BA

E3661B & E3662B Configurations

The Agilent E3661B (1.6 m, 32 EIA Units) and E3662B (2.0 m, 41 EIA Units) rack cabinets have a variety of options. Each rack is delivered fully assembled and ready to use. Each rack comes with sides, vented rear door, and one PDU (either 110v or 220v).

Factory installed PDUs are available in a 100-120V North American configuration (AW3) or a 200-240V International configuration (AW5). See the table on page 11 for descriptions and ordering information.

You can add a second PDU easily at a later date. See pages 9 and 13 for details.



E3661B

What you get in the box

Rack cabinet (assembled with vented top, solid base)

Leveling screws

Retractable anti-tip foot

4 3-inch heavy duty casters

One System II rail kit (one set of Agilent instrument rails)

Factory installed vented, lockable rear door.

Factory installed solid side panels. Easily removable.

Factory installed PDU

Option AW3 for 110V or option AW5 for 220V

Forehead bezel with lighted safety switch

Rack Cabinets

► 1.6 m and 2.0 m Rack Cabinets E3661B and E3662B

Description of Factory Installed Options	E3661B*	E3662B*
PDU's include: Forehead bezel with lighted switch, dual circuit breakers, IEC-320 upper receptacle for fan or other use.	1.6 m 32 EIA	2.0 m 41 EIA
North American PDU 100-120V, 16A 1 IEC-320 C-13 and 9 NEMA 5-15R Receptacles, 2 m cord with 5-20P non-locking plug (To add a 2nd PDU by yourself, order accessory E4455AZ)	E3661B + Option AW3	E3662B + Option AW3
International PDU 200-240V, 16A 1 IEC-320 C-19 and 10 C-13 Receptacles, 2 m cord with no plug, user installs local plug (To add a 2nd PDU by yourself, order accessory E4457BZ)	E3661B + Option AW5	E3662B + Option AW5



IEC-320 C13

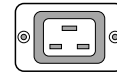

IEC-320 C19



NEMA 5-15R

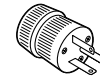

5-20P non-locking

Must read box

E3661B & E3662B Racks require one option

PDU option

(AW3 or AW5)

*NOTE: order option AW1 for a rack with no sides, rear door, or PDU. If AW1 is ordered, then the accessories must be purchased and installed separately.

Configuration Examples

Rack with sides, door and PDU (100-120V) :
model + AW3 (100-120V PDU)

Rack with sides, door and PDU (200-220V) :
model + AW5 (200-240V PDU)

Agilent Rack Model	Ht. (m)	EIA Units	Power Distribution Options	
			AW3 – 100-120V US plug	AW5 – 200-220V no plug
E3662B	2.0	41	AW3	AW5
E3661B	1.6	32	AW3	AW5

Contacting Agilent Regional Offices & Call Centers: See the back cover of this catalog for a list of local and regional sales offices near you.

On the Worldwide Web:
www.agilent.com/find/contactus

For additional information on racks please visit our web site:
www.agilent.com/find/enclosures

Ordering Parts:
www.parts.agilent.com

Rack Cabinets

► Multi-Bay Systems Kits

Multi-Bay System Configurations

Agilent tie kits allow you to create multi-bay solutions. These kits connect rack columns, and provide clearance for front and rear door operation. Start by filling in the configuration guide (left) and then select the kits for your application.

Multi-bay System Tie Kits

Tie kits include cosmetic panels which connect and finish the front, rear and top of adjacent racks. Order one tie kit for each pair of racks to be joined.

Tie Kit Ordering Information

- E4467BZ 1.3 m
- E4467BZ 1.6 m
- E7792AZ 2.0 m

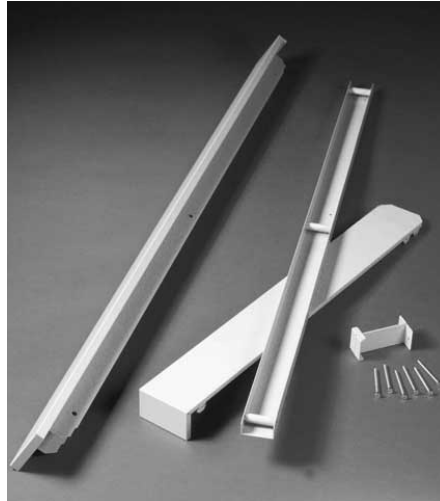

Tie kit (E4467BZ 1.6 m)



- What you get in the box**
- 1 Rear tie
 - 1 Front tie
 - 1 Top tie
 - All mounting hardware

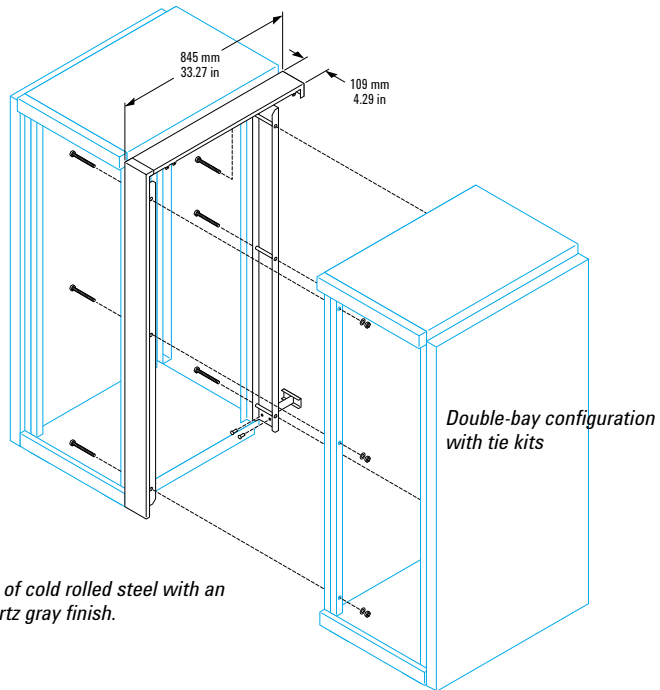

► Power Distribution Units (PDUs)

The power distribution unit conveniently supplies power to equipment mounted in the rack. The PDU is available in 110 or 220 volt options to accommodate American and international environments. The PDU is mounted vertically behind the rear column and does not reduce vertical mounting space in the rack.

A lighted master power switch is supplied with the PDU. The switch controls a relay in 1 or 2 PDUs. The system's power can be conveniently switched on and off using the master switch. The switch also provides rapid system shutdown in case of emergency. It uses low voltage signal lines for safety and to minimize electrical noise.

- Circuit breakers are provided on both hot (live) and neutral lines.
- All PDUs are single phase.
- A maximum of two PDUs can be installed in one rack.
- The top receptacle of all PDUs is configured as IEC-320 and is intended for the extractor fan. It can be used for other purposes if no fan is installed.
- We offer various power cords. See the power cord selection to select the power cord that is appropriate for your location and rack solution.



Power distribution units

Must Read Box

All racks come with a PDU (option AW3, 110V or AW5, 220V). A second PDU can be ordered per the chart below.

What you get in the box

- Power distribution unit
- Master power switch
- Power cord and plug

Ordering Information for Racks without Factory-Installed PDUs

Part No.	Description	Voltage	Region
E4451AZ	PDU for 1.3 m racks	100-120V	North America
E4453AZ	PDU for 1.3 m racks	200-240V	International
E4455AZ	PDU for 1.6 and 2.0 m racks	100-120V	North America
E4457BZ	PDU for 1.6 and 2.0 m racks	200-240V	International

Rack Accessories

PDU Specifications

PDUs for 1.3 m (E7590A) Racks

	E4451AZ (North America)	E4453AZ (International)
Voltage	100-120V	200-240V
Maximum Current	16amps	16amps
Power Cord Length	2 m (78.74 in)	2 m (78.74 in)
Plug	5-20P non-locking 	No plug; cord is undetermined

Receptacle Types:



NEMA 5-15R

5
NEMA 5-15R Receptacles

—



IEC-320 C13

1
IEC-320 C13 Receptacle

6
IEC-320 C13 Receptacles

Standards	Meets UL/CSA standards	Meets IEC-950 and VDE standards
-----------	------------------------	---------------------------------

PDUs for 1.6 m (E3661B) and 2.0 m (E3662B) Racks

	E4455AZ (North America)	E4457BZ (International)
Voltage	100-120V	200-240V
Maximum Current	16amps	16amps
Power Cord Length	2 m (78.74 in)	2 m (78.74 in)
Plug	5-20P non-locking 	No plug; cord is undetermined

Receptacle Types:



NEMA 5-15R

9
NEMA 5-15R Receptacles

—



IEC-320 C13

1
IEC-320 C13 Receptacle

10

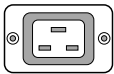

IEC-320 C19

—

1
IEC-320 C19 Receptacle

Standards	Meets UL/CSA standards	Meets IEC-950 and VDE standards
-----------	------------------------	---------------------------------

Rack Accessories



Plexiglas® front door (E4462BZ)

◀ Plexiglas® Front Door

Protect your equipment with a full length Plexiglas front door. An attractive, transparent smoke-colored Plexiglas front door provides a consistent appearance to the rack and is lockable to control access to the instruments and peripherals mounted in the rack. The front door is also useful for keeping equipment free from dust.

The Plexiglas Front Door offers the following features:

- Can be installed to hinge on either the left or right side for maximum flexibility.
- Fast, easy customer installation.
- Doors include all necessary mounting hardware.
- Provides 64 mm (2.52 in) space to accommodate instrument front panels.
- Does not interfere with access to the master power switch.
- Mounts into an outer set of holes on the front columns and does not interfere with EIA mounting holes.
- Spacers between the door frame and Plexiglas create an airflow space.

Must Read Box

An extractor fan is strongly recommended to assist cooling when a front door is mounted. See page 17.

Ordering Information

Part No.	Description
E4461BZ	Plexiglas front door for 1.3 m rack
E4462BZ	Plexiglas front door for 1.6 m rack
E4463BZ	Plexiglas front door for 2.0 m rack

What you get in the box

Door assembly with Plexiglas window
Mounting hardware

Specifications

	E4461BZ	E4462BZ	E4463BZ
Material	Cold-rolled steel	Cold-rolled steel	Cold-rolled steel
Weight	10 kg (22 lbs)	10.4 kg (23 lbs)	10.8 kg (24 lbs)
Color	Quartz gray	Quartz gray	Quartz gray
Height	1114 mm (43.9 in)	1425 mm (56.1 in)	1825 mm (71.9 in)
Depth	60 mm (2.4 in)	60 mm (2.4 in)	60 mm (2.4 in)
Width	513 mm (20.2 in)	513 mm (20.2 in)	513 mm (20.2 in)
Compatibility	1.3 m rack, bare rack	1.6 m rack, bare rack	2.0 m rack, bare rack

Rack Accessories

► Rear Doors

Standard racks include vented rear doors. To replace, a solid door should be ordered.

Features of the rear door kit include:

- Can be installed to hinge on either the left or right side for maximum flexibility.

- Easy customer installation.
- All necessary mounting hardware.
- Lockable for access security.

Mounting hardware is included with the rear door. However, you may also purchase a separate rear door hinge (see p/n C2786-00012C) if desired.

What you get in the box

- 1 Solid rear door
- 1 Latch catch
- Mounting hardware

Specifications – Solid Rear Doors

	E4476BZ	E4478BZ
Material	Cold-rolled steel	Cold-rolled steel
Weight	15.4 kg (34 lbs)	21.3 kg (47 lbs)
Color	Quartz gray	Quartz gray
Height	1425.6 mm (57.2 in)	1852.7 mm (72.9 in)
Width	599 mm (23.6 in)	599 mm (23.6 in)
EIA Units	32	41
Compatibility	1.6 m rack, bare rack	2.0 m rack, bare rack

Ordering Information – Solid Rear Doors

Part No.	Description
E4476BZ	Solid rear door for 1.6 m rack
E4478BZ	Solid rear door for 2.0 m rack

Specifications – Vented Rear Doors

	E4477BZ	E4479BZ
Material	Cold-rolled steel	Cold-rolled steel
Weight	14.1 kg (31 lbs)	20 kg (44 lbs)
Color	Quartz gray	Quartz gray
Height	1425.6 mm (57.2 in)	1852.7 mm (72.9 in)
Width	599 mm (23.6 in)	599 mm (23.6 in)
EIA Units	32	41
Compatibility	1.6 m rack, bare rack	2.0 m rack, bare rack

Ordering Information – Vented Rear Doors

Part No.	Description
E4477BZ	Vented rear door for 1.6 m rack
E4479BZ	Vented rear door for 2.0 m rack

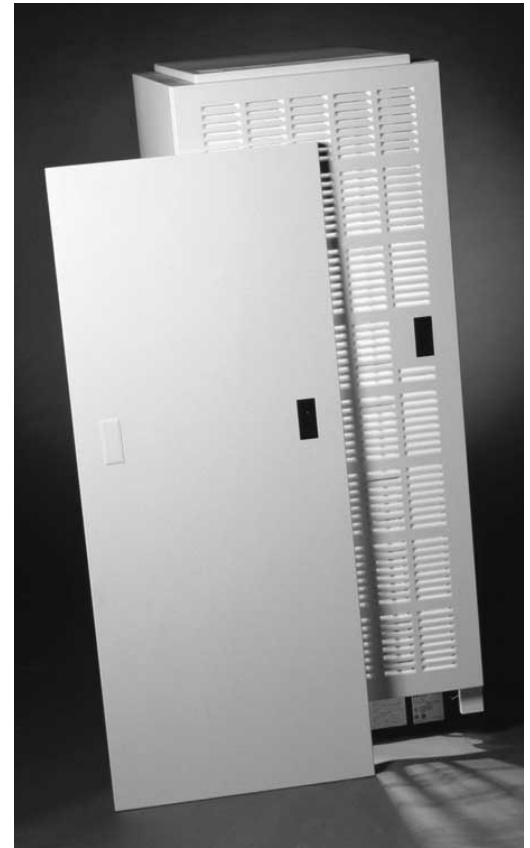

Solid and vented rear doors (E4476BZ, E4477BZ)

What you get in the box

- 1 Vented rear door
- 1 Latch catch
- Mounting hardware

Rack Accessories

What you get in the box

- 1 Fan
- Mounting hardware

► Extractor Fans – 200 cfm

Extractor fans are used to increase air flow through the rack cabinet. Agilent’s fan improves natural convection cooling by increasing the airflow in the rack. Use of the fan enhances the movement of warm air from the bottom of the rack up and out through the vented top cap, providing cooling to the entire length of the rack.

The customer installable extractor fan mounts easily under the top cap into the top frame of the rack. It moves air at 342 cubic meters per hour (200 cubic feet per minute). The fan does not reduce the space available for rackmounting instruments.

- Use when rack internal temperatures are 15°C (27°F) above ambient.
- Fans are highly recommended for racks with a front door.
- One fan per rack.
- Select an appropriate fan that fits your local AC voltage.
- Fans plug into the upper IEC 320 outlet on PDU.

Ordering Information

Part No.	Description
E4470AZ	100/120V 200 cfm extractor fan, fits all racks
E4471AZ	200/240V 200 cfm extractor fan, fits all racks



Extractor fan installed in rack

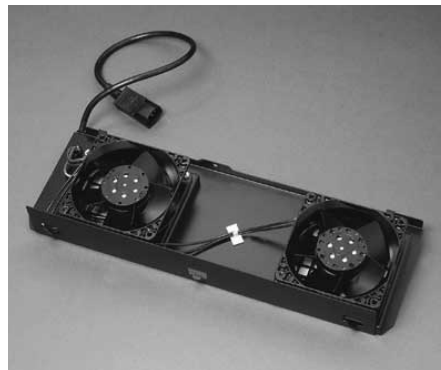

Extractor fan (E4470AZ)

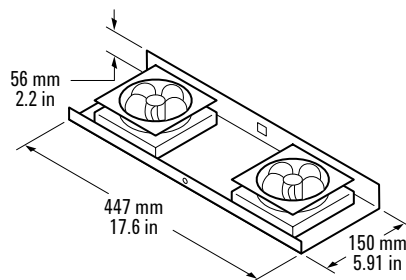

Specifications

	E4470AZ/E4471AZ (200 cfm)
Airflow	200 cfm (342 cmh)
Acoustic noise	43 dB
AC input	100/120V or 200/240V (50-60 Hz)
AC current	1 ampere maximum

	E4470AZ/4471AZ
Material	Cold-rolled steel
Weight	3.6 kg (8 lbs)
Color	Quartz gray
Length	150 mm (5.91 in)
Height	56 mm (2.2 in)
Width	447 mm (17.6 in)

Rack Accessories

► Drawers

Mount a drawer in the rack to keep manuals or spare cables close to where they are needed. Two drawer sizes are available. Sliding rails and mounting hardware are included.



Drawer (35181M)



Drawer installed in rack

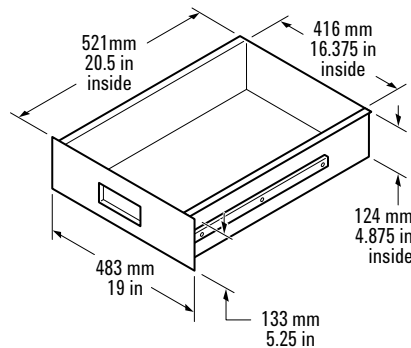

35181M Drawer

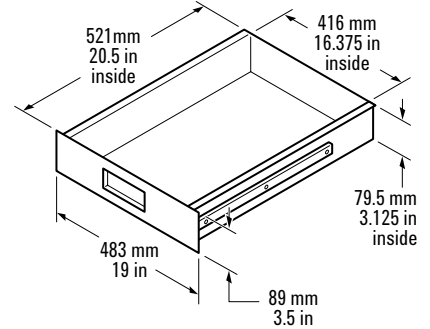

35181J Drawer

What you get in the box

- Drawer with slides attached
- Mounting hardware

Specifications

	35181J	35181M
Material	Cold-rolled steel	Cold-rolled steel
Weight	7.26 kg (16 lbs)	8.16 kg (18 lbs)
Color	Quartz gray	Quartz gray
Length	521 mm (20.5 in)	521 mm (20.5 in)
Height	89 mm (3.5 in)	133 mm (5.25 in)
Width	483 mm (19 in)	483 mm (19 in)

Ordering Information

Part No.	Description	Height Dimensions	EIA Units
35181J	Storage drawer, 3.5"	89 mm (3.5 in)	2
35181M	Storage drawer, 5.25"	133 mm (5.25 in)	3

Rack Accessories

► Stationary Shelf

This light-duty fixed shelf is designed to support equipment that does not have a rackmount kit. The shelf can be used in all standard Agilent racks. The stationary shelf is mounted securely into place using the supplied hardware and is designed to sit at the bottom of the EIA increment.

Attractive features of the stationary shelf include:

- Snap-in design for easy installation
- Smooth edges

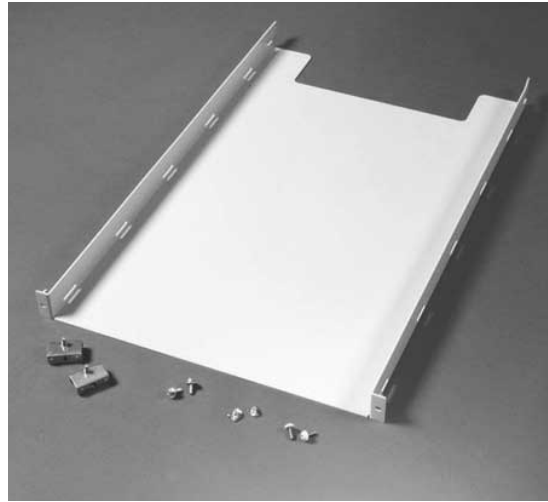

Stationary shelf (J1520AC)

Ordering Information

Part No.	Description	EIA Units
J1520AC	Stationary shelf	1

Specifications

J1520AC	
Material	Cold-rolled steel
Weight	8 kg (17.6 lbs)
Color	Quartz gray
Length	678 mm (26.7 in)
Height	44 mm (1.73 in)
Width	444 mm (17.5 in)
Load Capacity	68 kg (150 lbs)

What you get in the box

- 1 Stationary shelf
- 2 Rear brackets
- Mounting hardware

► Sliding Shelf

The sliding shelf provides a flat surface with full product accessibility. It can be used in all Agilent racks to support equipment that may not have its own rackmount kit. The shelf and slides are preassembled for easy installation.

Attractive features of the sliding shelf include:

- Snap-in design for easy installation
- Smooth edges

Consider purchasing the steel ballast (C2790AC) to use with the sliding shelf. The ballast provides anti-tip capability when the shelf is extended.



Sliding shelf installed in rack

Specifications

J1526AC	
Material	Cold-rolled steel
Weight	9.9 kg (22 lbs)
Color	Quartz gray
Length	723.9 mm (28.5 in)
Height	44.5 mm (1.75 in)
Width	482.6 mm (19 in)
Load Capacity	68 kg (150 lbs)

What you get in the box

- 1 Sliding shelf
- 2 Rear brackets
- 1 Cable strap
- Mounting hardware

Ordering Information

Part No.	Description	EIA Units
J1526AC	Sliding shelf	2



Sliding shelf (J1526AC)

Rack Accessories

► Work Surface

The work surface is stationary and is designed to remain securely in place. The work surface provides a convenient work shelf utility area at the front of the rack. It can be used as a writing space or to hold accessories.

Consider purchasing the steel ballast (C2790AC) to use with the work surface. The ballast provides anti-tip capability.

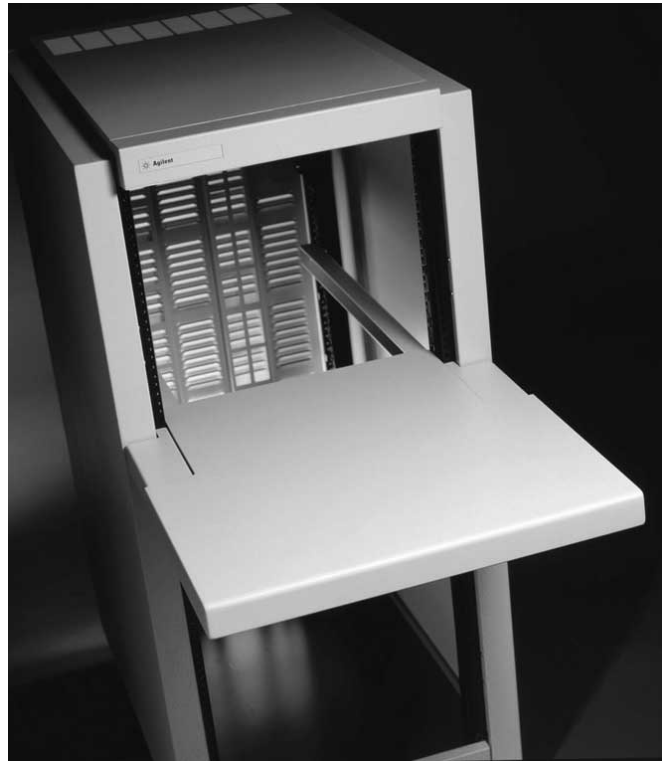

Work surface installed in rack

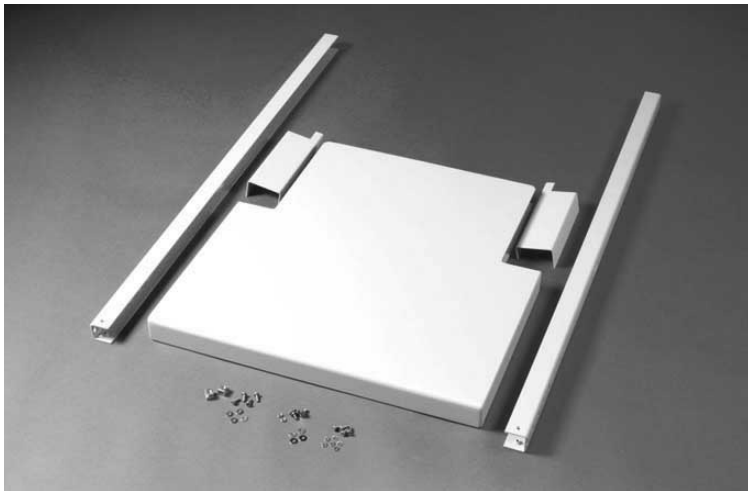

Work surface (46298SZ)

What you get in the box

- Work surface
- 2 Support rails
- 2 Left, 2 right filler rail panels
- Mounting hardware

Ordering Information

Part No.	Description	EIA Units
46298SZ	Work surface	2

Specifications

46298SZ	
Material	Cold-rolled steel
Weight	12.7 kg (28 lbs)
Color	Quartz gray
Depth	610 mm (24 in.) to 387 mm (15.24 in.)
Width	600 mm (23.6 in.)
Load Capacity	22.7 kg (50 lbs)

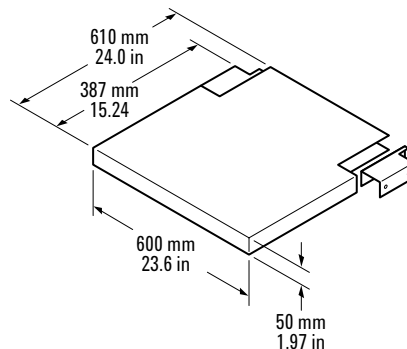

Rack Accessories

► Ballast

A ballast kit includes a 30 pound weight to provide anti-tip protection. Ballast deters the cabinet from tipping forward if heavy slide-mounted devices are extended from the rack.

Agilent rack cabinets include a standard, pull-out anti-tip foot that can be extended temporarily for servicing. Ballast provides an extra margin of safety to counteract the extra weight incurred when of an accessory that extends from the rack, such as a work surface.

- Each ballast kit contains a 30 lb. ballast and mounting hardware.
- The ballast mounts on the rear columns of the rack and provides a counterweight for equipment that extends out from the front of the rack.

Ballast should be employed when using the following rack accessories:

- Slide mounted instruments
- Work surface
- Monitor
- Keyboard

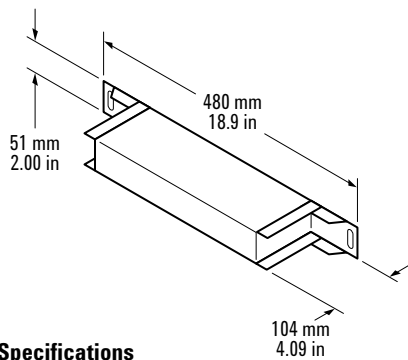

Specifications

	C2790AC
Material	Cold-rolled steel
Weight	13.6 kg (30 lb)
Color	Quartz gray
Length	104 mm (4.1 in)
Height	51 mm (2.0 in)
Width	480 mm (18.9 in)

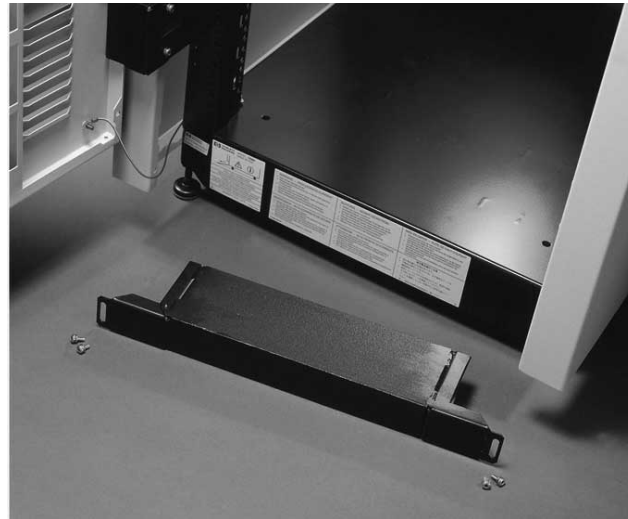

Ballast standard mounting (C2790AC)

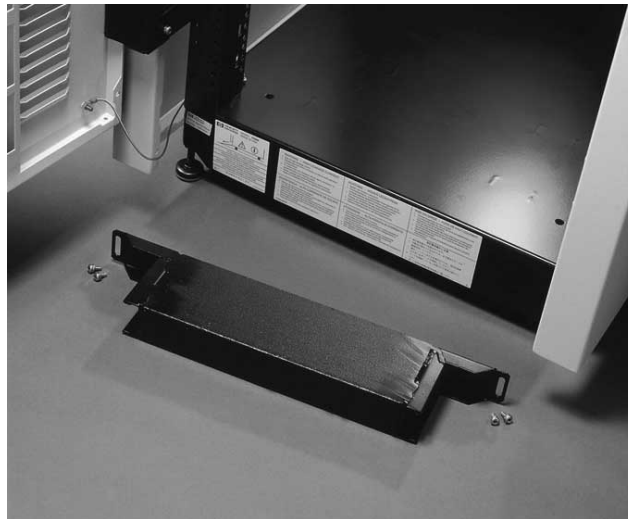

Ballast, alternate mounting (C2790AC)

Must Read Box

Always mount ballast in the rear of the rack. Racks should not be shipped with ballast installed.

What you get in the box

- Ballast
- Mounting hardware

Ordering Information

Part No.	Description
C2790AC	30 lb steel, fits all rack heights

Three Rackmount Kits

Monitor Rackmount Kits

► Monitor Rackmount Kit

Safely and securely install your monitor with the Agilent monitor rackmount kit. The Agilent monitor rackmount kit can accommodate 14" to 19" monitors. The kit consists of a shelf, all required mounting hardware, and cosmetic panels around the monitor.

Consider purchasing the steel ballast (C2790AC) to use with the monitor rackmount kit. The ballast provides anti-tip capability when the shelf is extended.

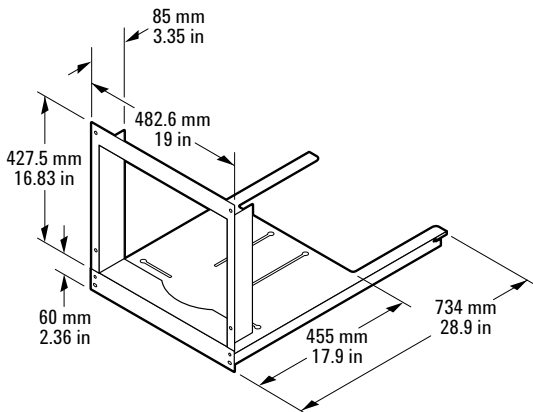

Monitor rackmount kit installed in rack (monitor not included)

What you get in the box

- 1 Monitor base
- 1 Front bezel
- 2 Rear brackets
- Mounting hardware



Monitor rackmount kit (J1519BC) installed with fixed keyboard kit (E7714AC) (monitor not included)

Specifications

	J1519BC
Material	Cold-rolled steel
Weight	5.9 kg (13 lbs)
Color	Quartz gray
Height	427.5 mm (16.83 in)
Depth	734 mm (28.9 in.)
Width	482.6 mm (19 in.)
Load Capacity	45 kg (100 lbs)
EIA Units	11

Ordering Information

Part No.	Description	EIA Units
J1519BC	Monitor rackmount kit, fits 14-19 inch monitors	11



Monitor rackmount kit (J1519AC)

Rackmount Kits

Keyboard and Mouse Rackmount Kits

Select a fixed or retractable keyboard and mouse kit appropriate for your needs. Keyboard and mouse are not included. Consider purchasing the steel ballast (C2790AC) to use with your keyboard and mouse kit. The ballast provides anti-tip capability when the shelf is extended.

Keyboard and Mouse Rackmount Kits

▶ Retractable Keyboard Kit

Agilent's compact shelving kit provides a convenient enclosed keyboard system that requires minimum rack space, saving valuable space for your instruments. The kit can accommodate any standard keyboard and mouse. The retractable keyboard shelf slides into the rack when not in use. When retracted, the shelf does not extend from the rack. Keyboard security is available by using a front door on the rack cabinet. The keyboard kit includes all mounting hardware.

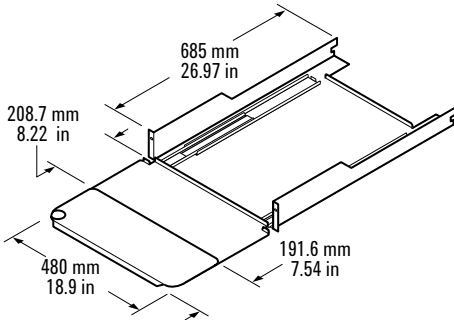

Specifications

J1518AC	
Material	Cold-rolled steel
Weight	12.9 kg (28.5 lbs)
Color	Quartz gray
Depth	685 mm (26.97 in.)
Width	480 mm (18.9 in.)
Load Capacity	22.7 kg (50 lbs)
EIA Unit	2

Ordering Information

Part No.	Description	EIA Units
J1518AC	Retractable keyboard kit, fits all racks	2



Retractable keyboard kit, retracted in rack



Retractable keyboard kit installed in rack

What you get in the box

- 1 keyboard kit assembly
- 2 Rear brackets
- Mounting hardware
- Mouse pad



Retractable keyboard kit (J1518AC)

Rackmount Kits

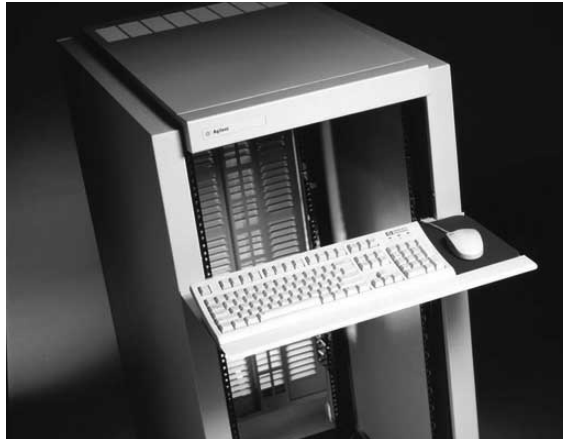

Fixed keyboard kit installed in rack

Keyboard and Mouse Rackmount Kits

◀ Fixed Keyboard Kit

The keyboard kit includes all mounting hardware. In an environment where the keyboard is not required to retract, a fixed keyboard shelf is available. The fixed keyboard shelf mounts on the outside of the front rack columns.

Must Read Box

The fixed keyboard cannot be used with a front door installed on the rack.



Fixed keyboard kit installed in rack with monitor rackmount kit (monitor not included)

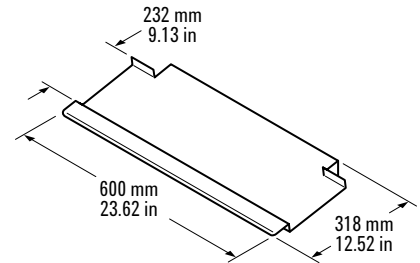

What you get in the box

1 Fixed keyboard kit assembly

Mounting hardware

Mouse pad



Fixed keyboard kit (E7714AC)

Specifications

E7714AC	
Material	Cold-rolled steel
Color	Quartz gray
Depth	318 mm (12.52 in)
Width	600 mm (23.62 in.)
EIA Unit	1

Ordering Information

Part No.	Description	EIA Units
E7714AC	Fixed keyboard kit, fits all racks	1

Rackmount Kits

Instrument Rackmount Kits

▶ Instrument Compatibility with Racks

Agilent's Modular Cabinets (System II)

Agilent's modular cabinet system offers bench-stacking and rackmounting versatility. These cabinets are designed for compatibility with EIA and IEC standards, both in width and height.

Modular cabinets are currently defined as System II and System II Plus instruments. These are identical in form, fit and function. The only difference is the color.

System II and System II Plus cabinets are available in standard sizes. As shown in the illustration, instrument depths have 5 sizes and instrument heights have 6 sizes. They are measured in millimeters and inches.

The instrument width is measured in module width (MW). The module width measurement is an important feature for determining rackmounting requirements. 1 MW is equivalent to the full width of the rack.

Most equipment can be ordered with handles and flanges at the time the equipment is ordered. If you have an instrument without the necessary hardware, then use the following pages to add flanges and handles.

Mounting Other Instruments

Some Agilent instruments use non-System II cabinets. These products typically have rackmounting options. See the specific product's data sheet for those details.

Non-Agilent instruments that comply with the industry-standard units may be easily rackmounted as well.

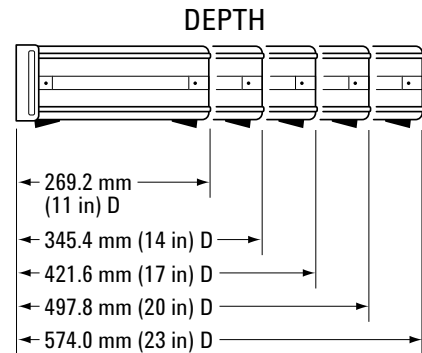
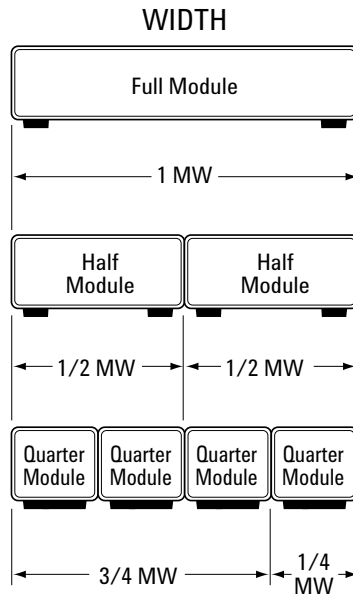
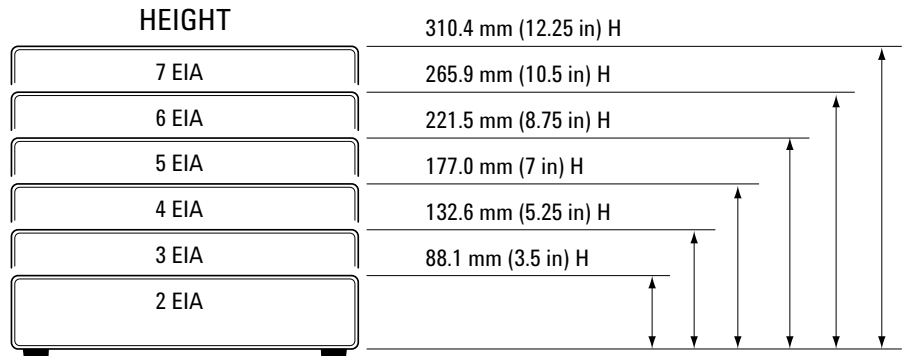

Must Read Box

The instrument rackmount kits, shown on pages 25-30, include metric fasteners to make them compatible with metric-fastener cabinets. Metric-fastener cabinets are identified with a "metric" embossment in the front bezel casting under the plastic trim strip and on the middle of the rear bezel casting.

Rackmount Kits

Instrument Rackmount Kits

Handles and Rackmount Flanges

Handles and rack flanges are available for all System II cabinets. They find most use on full width modules or combinations of narrower modules locked together to form one module width (MW). See page 26 for information about module widths and instrument heights and depths.

Flanges secure the instrument to the front mounting column of the rack. All Agilent flange kits attach to the instrument using pre-existing holes in the

instrument case. Flanges alone will not support the weight of an instrument in the rack. The appropriate rails or slides must be purchased for support.

Certain instruments are supplied with front handles as part of the selling price. Handles and rack flanges can be supplied with most instruments for an added cost by specifying the appropriate option at the time of order.

Alternatively, the equivalent mounting hardware may be ordered after receipt of the instrument using the information listed on the following page. These order options include:

- A** Front Handle Kit
- B** Rackmount Flange Kits
- C** Handles with Rack Flanges
- D** Flange Kit for Instruments with Previously Supplied Handles

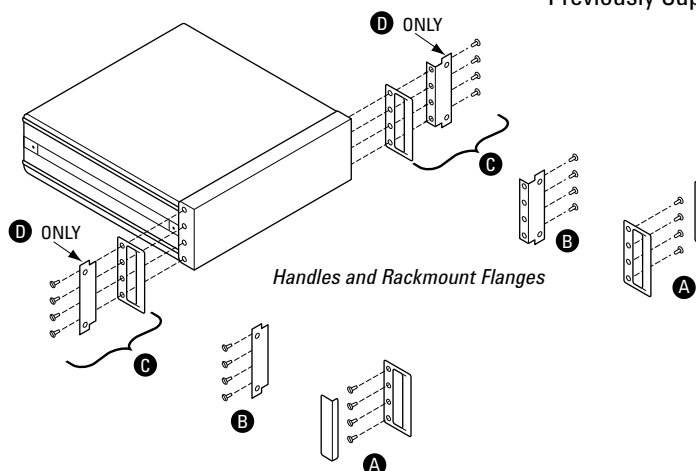

Must Read Box

The rackmount flange kits secure your instrument to the front columns of the rack. You must also select the appropriate rails or slides to support the weight of the instrument in the rack. See pages 33 & 34 for rail and slide information.



Front handle kit (5063-9229)

What you get in the box

- 2 Handles
- 2 Trim strips
- Metric fasteners

◀ Front Handle Kit

Order a front handle kit when your instrument does not come with pre-installed handles. Check to make sure your instrument requires handles, as many instruments are supplied with previously installed handles.

- Flanges attach to pre-existing holes in the instrument case

Rackmount Kits

Instrument Rackmount Kits

► Rackmount Flange Kits

Flange kits are available for all System II instruments. Flanges attach to pre-existing holes in the instrument case. These flanges do not have a notch for handles, and therefore cannot be used for instruments that have handles.

- Flanges attach to pre-existing holes in the instrument case

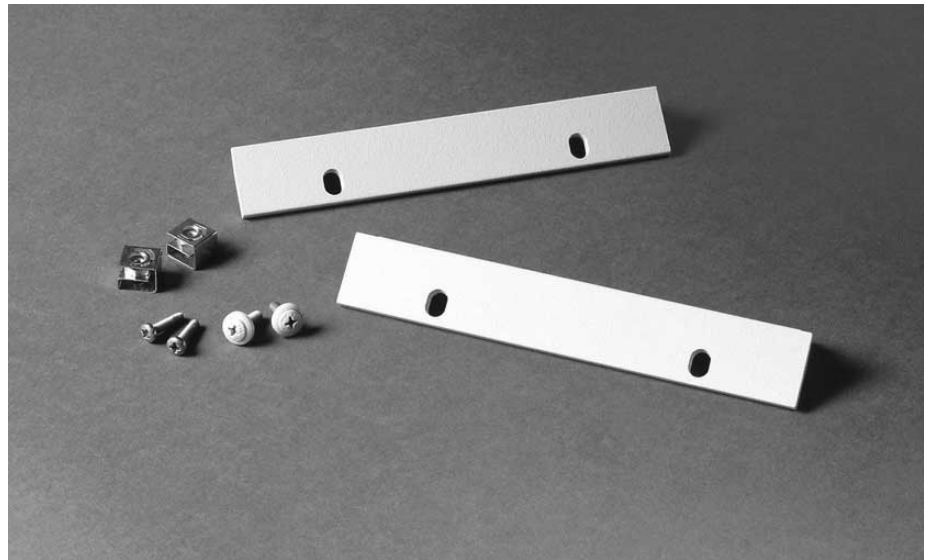

Rackmount flange kit (5063-9216)

What you get in the box

- 2 Flanges
- Metric fasteners
- Mounting screws



Flange kit with handles (5063-9223)

◀ Flange Kit with Handles

This kit includes both flanges and handles.

- Flanges attach to pre-existing holes in the instrument case

What you get in the box

- 2 Handles
- 2 Flanges
- Metric fasteners
- Mounting screws

Rackmount Kits

Instrument Rackmount Kits

▶ Rackmount Flange Kit for Instruments with Previously Supplied Handles

Certain Agilent instruments are supplied with front handles. These flange kits have a special cut out to accommodate the handles.

- Flanges attach to pre-existing holes in the instrument case

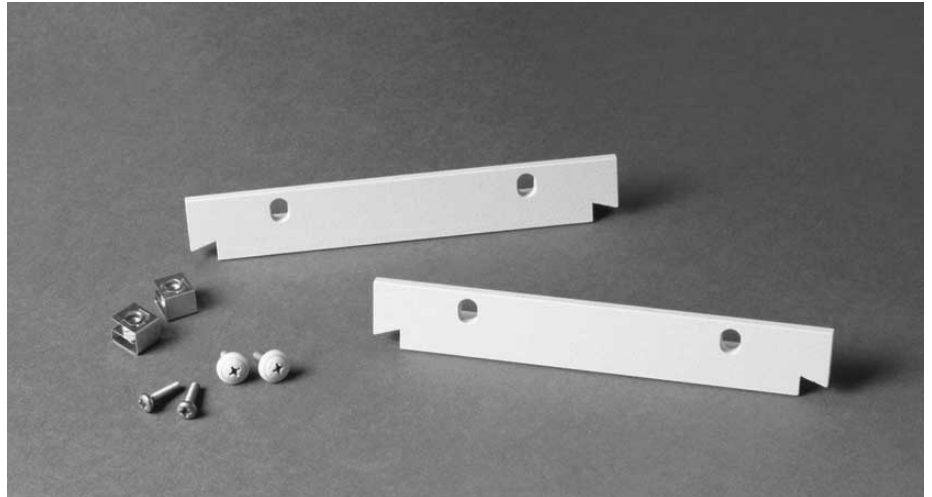

Rackmount flange kit for instruments with previously supplied handles (5063-9236)

What you get in the box

- 2 Flanges
- Metric fasteners
- Mounting screws

Selecting a Rackmount Flange or Handle Kit

The table below lists the kits available for use after receipt of the equipment. Field installation is straightforward.

- A plastic trim strip is easily removed and the handle or flange attaches with screws supplied in the kit.
- Before rackmounting, bottom feet must be removed.

Ordering Information

Instrument Module Height	A Front Handle Kit	B Rackmount Flange Kit ¹	C Flange Kit with Handles	D Flange Kit for Instruments w/Previously Supplied Handles
88.1 mm (3.5 in)	5063-9226	5063-9212 ¹	5063-9219 ¹	5063-9232 ¹
88.1 mm (3.5 in)	—	5063-9213 ²	5063-9220 ²	—
132.6 mm (5.25 in)	5063-9227	5063-9214	5063-9221	5063-9234
177.0 mm (7.0 in)	5063-9228	5063-9215	5063-9222	5063-9235
221.5 mm (8.75 in)	5063-9229	5063-9216	5063-9223	5063-9236
265.9 mm (10.5 in)	5063-9230	5063-9217	5063-9224	5063-9237
310.4 mm (12.25 in)	—	5063-9218	5063-9225	—
Kit includes	2 handles 2 trim strips metric fasteners	2 flanges metric fasteners mounting screws	2 handles 2 flanges metric fasteners mounting screws	2 flanges metric fasteners mounting screws

¹The following kits use standard flanges with 1.75 in hole spacing: 5063-9212/9219/9232

²The following kits use special flange with 3 in hole spacing: 5063-9213/9220

³Will not fit onto instruments with previously supplied handles

Rackmount Kits

Instrument Rackmount Kits

► Rackmount Adapter Kits

Rackmount adapter kits are available to mount an instrument, or combination of instruments, that is less than one full module width (MW).

- Individual 1/4 MW or 1/2 MW modules use the kits shown in the table below.
- Combinations of 1/4 MW or 1/2 MW (of equal depth) are first joined side-by-side with the Lock Link Kit (see page 33 for PN 5061-9694). Combinations joined side-by-side must be the same depth and height. Then the rackmount adapter kit is applied. If modules are of unequal depth or height, a support shelf (as shown on page 31) can be used.
- For combinations of instruments adding to 1 MW, use the rackmount flange kit (see Selecting a Rackmount Flange or Handle Kit, page 27).
- Hole patterns conform to EIA and IEC standards.

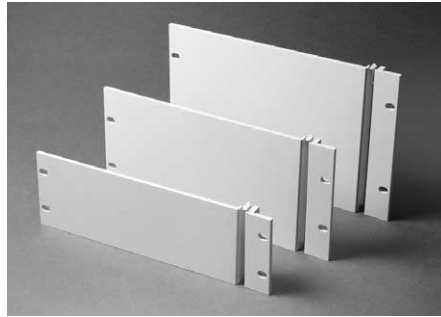

Rackmount adapter kits for 88.1 mm instrument module height (5063-9239, 5063-9240, 5063-9241)

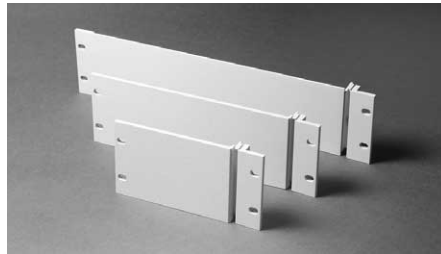

Rackmount adapter kits for 1/2 MW (5063-9240, 5063-9243, 5063-9245)



Rackmount adapter kit with mounting hardware (5063-9239)

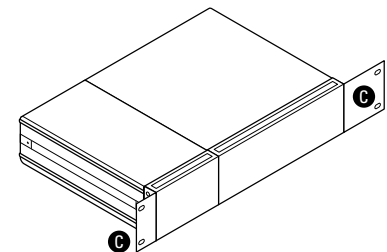
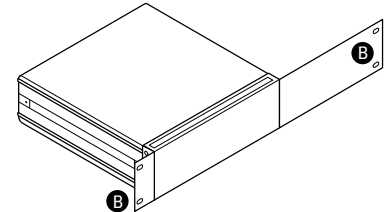
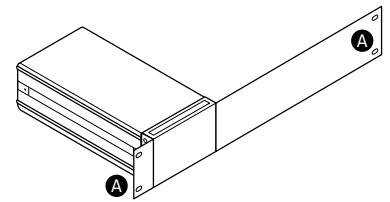

What you get in the box

- 1 Standard flange
- 1 Adapter flange
- Attaching screws
- Front-panel rackmounting screws

Ordering Information

Instrument Module Height	A Mounts 1/4 MW Modules	B Mounts 1/2 MW or 2 each 1/4 MW ¹ Modules	C Mounts 3/4 MW (3 each 1/4 MW ² or 1/4 & 1/2 MW side by side)
88.1 mm (3.5 in)	5063-9239	5063-9240	5063-9241
132.6 mm (5.25 in)	-	5063-9243	-
177.0 mm (7.0 in)	-	5063-9245	-
Kit includes	1 rack flange + 1/4 MW extension adapter flange + screws	1 rack flange + 3/4 MW extension adapter flange + screws	1 rack flange + 1/2 MW extension adapter flange + screws

¹Side by side modules of equal depth require a Lock Link Kit (5061-9694)

²1/4 MW can be center mounted using two of these kits

Rackmount Kits

Instrument Rackmount Kits

▼ Support Shelf, Filler Panels and Slide Kits

These shelves are available for instruments less than 1 MW.

- Submodules of differing heights, widths, and depths (up to 20 inches deep) can be rackmounted using these support shelves. Any combination of 1/4 MW and 1/2 MW will fit side-by-side up to 1 MW.

- The slide kit is required for installation of the support shelf. It provides ready access to internal shelf areas. The slide kit includes brackets and mounting hardware.
- Special filler panels are available to close up vacant spaces either on top of a short module or side-by-side.

What you get in the box

- Shelf
- Tie down clips
- Mounting hardware

Ordering Information – Support Shelf

Instrument Module Height	Part No.	Description
88.1 mm (3 1/2 in)	5063-9255	Support shelf
132.6 mm (5 1/4 in)	5063-9256	Support shelf
177.0 mm (7 in)	5063-9257	Support shelf
	1600-1424	Tie down clip replacement part

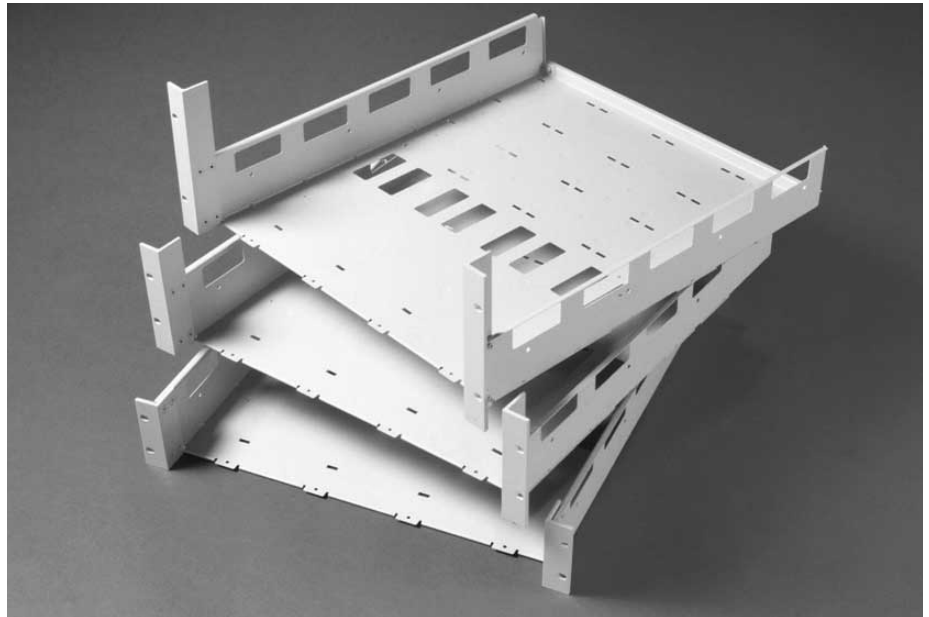

Support shelves, 3 different sizes

Specifications – Support Shelf

	5063-9255	5063-9256	5063-9257
Material	Cold-rolled steel	Cold-rolled steel	Cold-rolled steel
Weight	4.5 kg (10 lbs)	4.5 kg (10 lbs)	4.5 kg (10 lbs)
Color	Quartz gray	Quartz gray	Quartz gray
Length	527.6 mm (20.77 in.)	527.6 mm (20.77 in.)	527.6 mm (20.77 in.)
Height	88.9 mm (3.5 in.)	133.4 mm (5.25 in.)	177.8 mm (7 in.)
Width	489 mm (19.25 in.)	489 mm (19.25 in.)	489 mm (19.25 in.)
Load Capacity	22.7 kg (50 lbs)	22.7 kg (50 lbs)	22.7 kg (50 lbs)

Must Read Box

Adapter kits, handles or flanges are not required if a support shelf is used.

Rackmount Kits

Support Shelf, Filler Panels and Slide Kits (cont.)

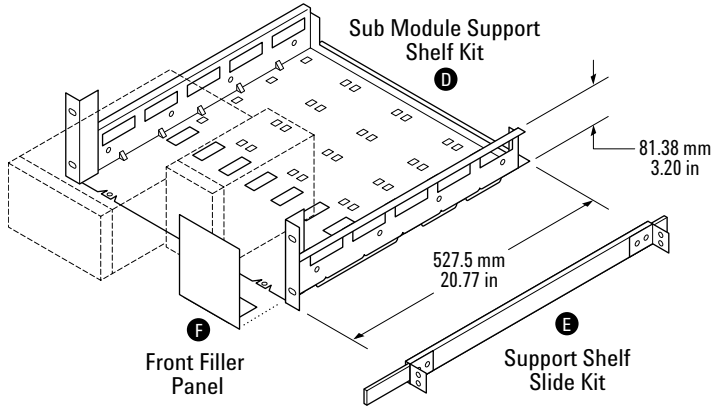

Ordering Information – Support Shelf Slide Kit

Instrument Module Height	Part No.	Description
All heights	1494-0015	Support shelf slide kit, required for installation of the support shelf.

What you get in the box

- Slide kit
- Mounting hardware

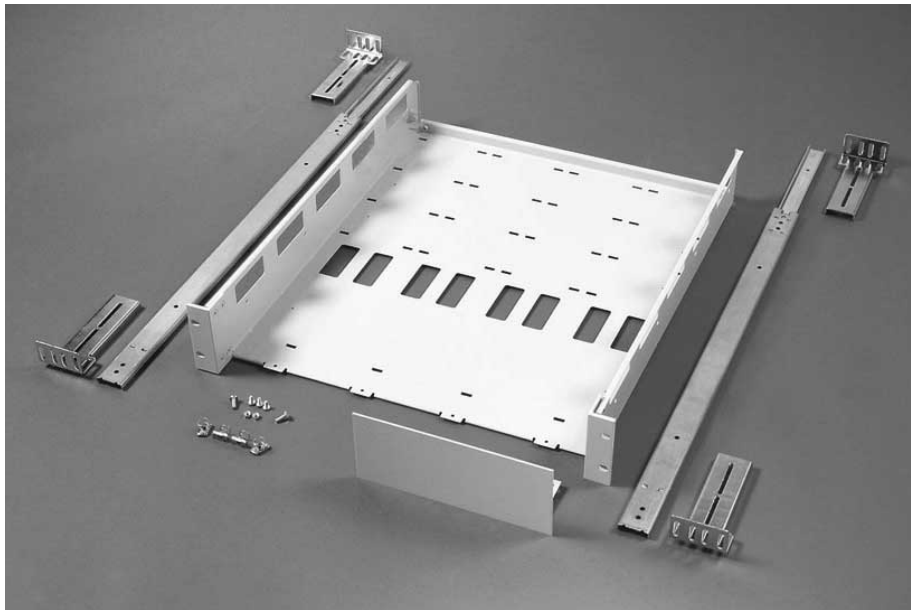

Support shelf (5063-9257), slide kit (1494-0015), and filler panel (5002-3999)

Ordering Information – Support Shelf Filler Panel

Part No.	Description	Fill size
5002-3999	For 88.1 mm (3 1/2 in) H support shelf partially filled with instruments, and having the front panel space to fill 1/2 MW.	1/2 MW
5002-4001	For 132.6 mm (5 1/4 in) H support shelf, and having the front panel space to fill 1/4 MW.	1/4 MW

What you get in the box

- Filler panel
- Mounting hardware

Rackmount Kits

Instrument Rackmount Kits

▼ Lock Link Kits and Locking Feet Kits

All submodule cabinets of equal depths can be linked together vertically or side-by-side with hardware in the lock link kit. Cabinet frames are already pre-threaded to allow quick assembly.

For side-by-side connections, the Lock Link Kit contains 12 front hooks and 6 rear links, enough for 3 side-by-side joints. For submodule vertical connections, the kit also contains 4 front

hooks and 4 rear links, enough for 2 over/under joints. The kit includes metric screws.

The Locking Feet Kit (5062-3999) is designed to accommodate full module vertical combinations of greater weight. The Lock Link Kit is recommended for only submodule vertical combinations, as well as side-by-side combinations.

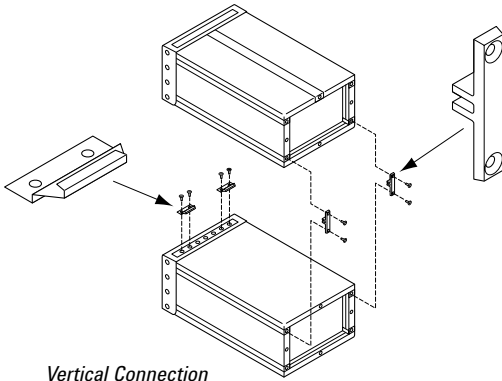

Vertical Connection

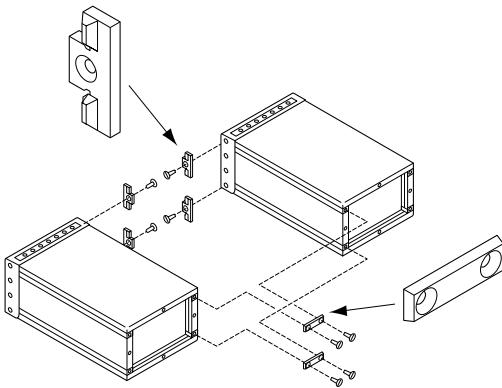

Side-by-side Connection

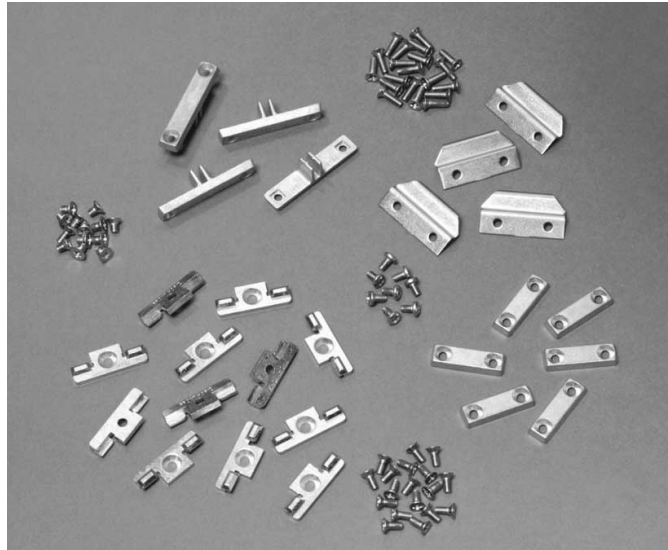

Lock link kit (5061-9694)

- What you get in the box – Lock Link Kits**
- 12 Front hooks
 - 6 Rear links
 - Mounting hardware



Locking feet kit (5062-3999)

Ordering Information

Part No.	Description
5061-9694	Lock link kit for linking submodule cabinets of equal height
5062-3999	Locking feet kit for full module vertical combinations

- What you get in the box – Locking Feet Kits**
- Locking feet
 - Mounting hardware

Rackmount Kits

Instrument Rackmount Kits

► Rail Kits

Agilent offers a variety of rail kits to meet instrument and controller rack mounting requirements.

Instrument rackmount kits alone are not designed to support the full weight of most instruments and may deform or break. Rails and slides are available to support the rear of the instrument.

Proper rail selection is important to maximize the use of all EIA units in a rack and to assure proper fit vertically between instrument front panels.

Agilent offers a set of support rails that can cut in half the time required to install equipment in a rack. The rails hang on discrete slots on the vertical mounting columns, corresponding to each EIA unit

in the rack. Vertical adjustment between instruments is minimized by selecting the proper rail. The system was specifically designed to minimize the time required to install Agilent instrumentation, and can be used with other equipment.

Rails will support up to 113 kg (250 lbs).

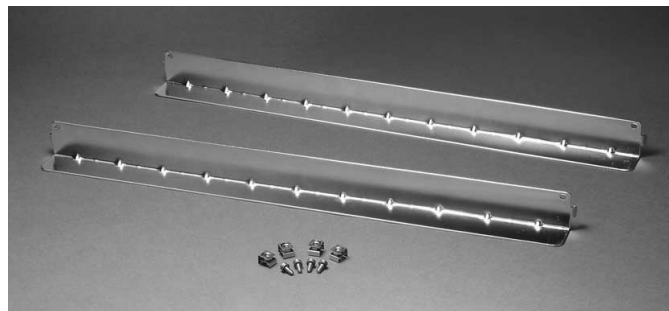
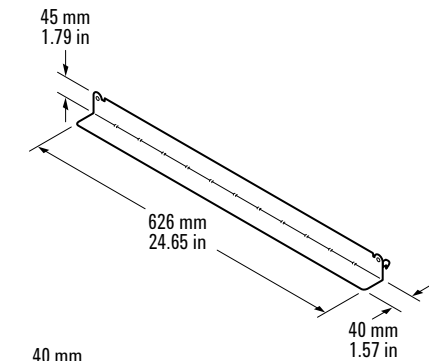

3rd party rail kit (E3664AC)

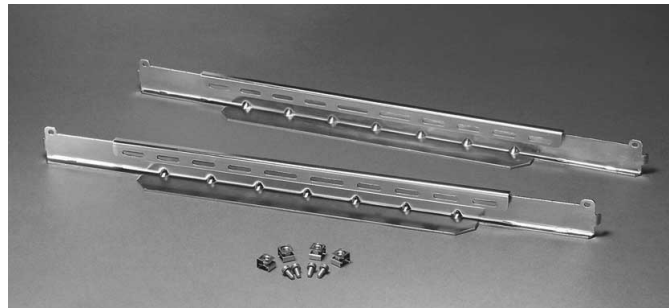
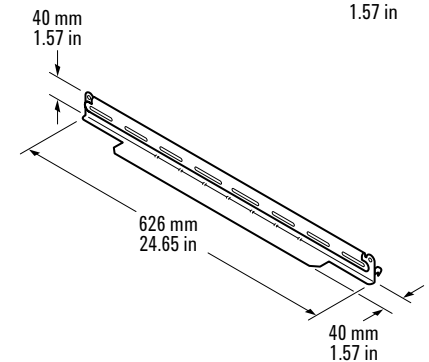

VXI rail kit (E3665AC)

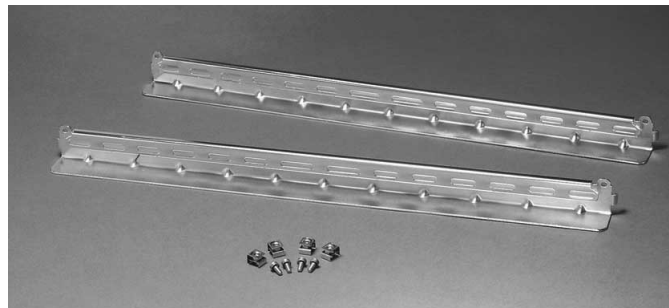
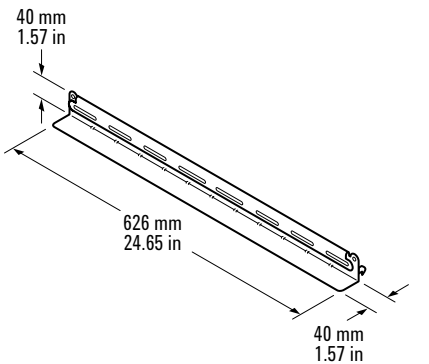

Basic rail kit (E3663AC)

What you get in the box

- 2 Rails
- Mounting hardware

Ordering Information

Part No.	Description
E3663AC	Basic Rail Kit (for System II instruments)
E3664AC	3rd Party Rail Kit
E3665AC	VXI Rail Kit

Rackmount Kits

Instrument Rackmount Kits

Slide Kits

Rack slides are available for full width System II cabinets to permit easy access to internal spaces. Each kit consists of two slides that mount directly to System II cabinet slide handle recess spaces (after removing the side handles). The slides also mount directly to vertical support columns in Agilent racks.

- Non-tilting standard-duty slides carry 38.6 kg (85 lb) maximum load.
- Non-tilting heavy-duty slides carry 79.3 kg (175 lb) maximum load.
- Slide kits are compatible with inch and metric instruments.

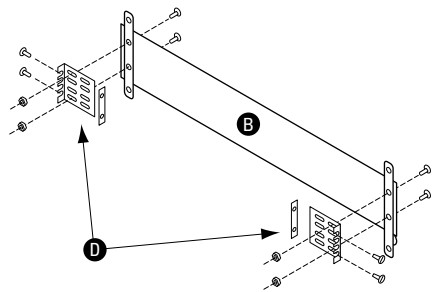

Heavy-duty slide kit (B) and non-Agilent rack heavy-duty slide bracket kit (D)

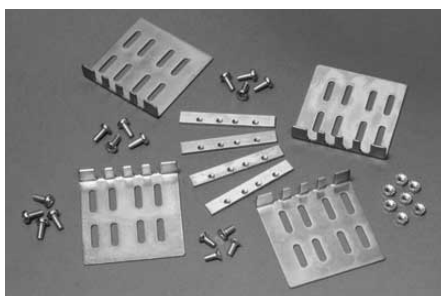

End brackets

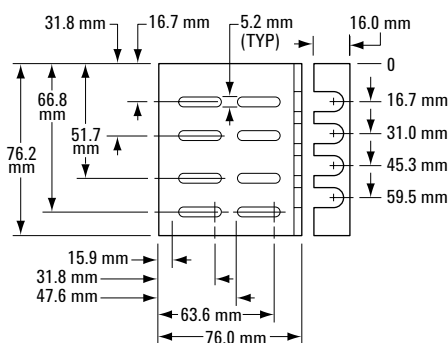

Non-Agilent heavy-duty slide bracket dimensions

Ordering Information

Part No.	Description	Instrument Depth
1494-0060	Slide kit: Non-tilting, standard duty	Fits 345.4 D and 421.6 D
1494-0059	Slide kit: Non-tilting, standard duty	Fits 497.8 D and 574.0 D
1494-0058	Slide kit: Non-tilting, heavy duty	Fits 345.4 D and 421.6 D



Slide kits (1494-0060, 1494-0059, 1494-0058, top to bottom)

What you get in the box

- 1 Slide assembly
- Mounting hardware

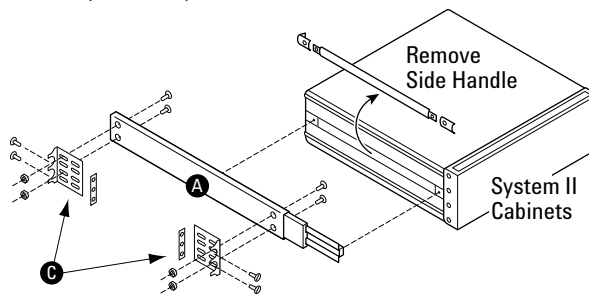

Slide kit (A) and standard slide bracket kit (C)

End Brackets

For non-Agilent racks, end-bracket kits are available for both Agilent standard- and heavy-duty slide kits. Slotted hole arrays in the brackets provide for front-to-back rack column spacing of up to a maximum of 609.45 mm (24 in) for standard slides and 688.9 mm (27.12 in) for the heavy-duty slides.

These general purpose mounting brackets fit most common non-Agilent racks that have L or U shaped columns with EIA standard hole patterns.

What you get in the box

- 4 Adapter brackets
- Mounting hardware

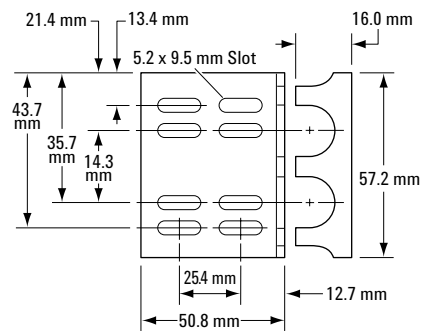

Standard slide bracket dimensions

Ordering Information

Part No.	Description
1494-0061	End brackets, standard duty
1494-0064	End brackets, heavy duty

Four Small Parts

► Feedthrough Panels

Feedthrough panels are available for use when cables or probes need to pass through from inside the rack to the front. Feedthrough panels include the necessary mounting hardware.

The feedthrough panel is 44 mm (1.74 in) high with two cutout grooves.

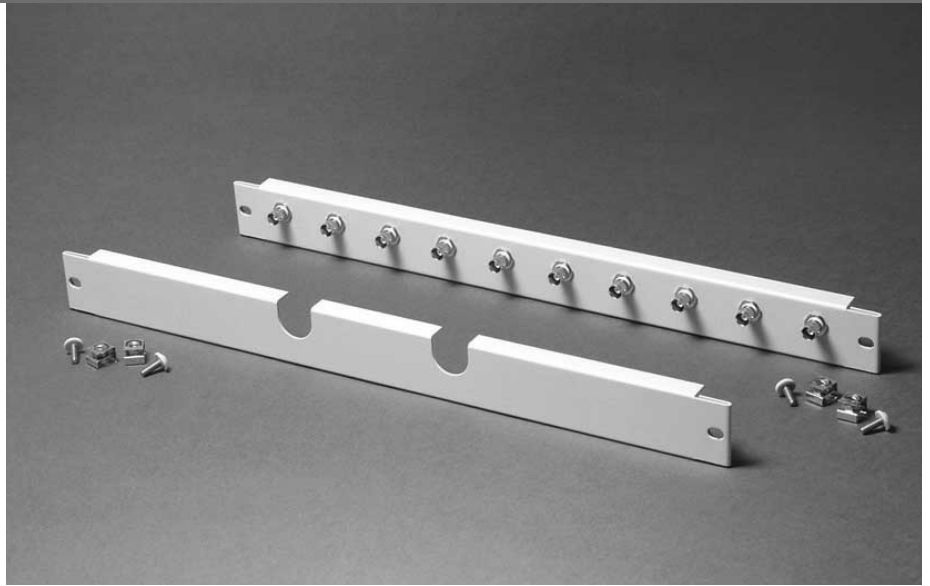

Feedthrough panel (E3668B) and BNC-BNC (f) to (f) panel (E3669B)

Specifications – Feedthrough Panel

	E3668B
Material	Cold-rolled steel
Weight	.45 kg (1 lb)
Color	Quartz gray
Length	439 mm (19 in)
Height	44 mm (1.74 in)
Width	44 mm (1.74 in)
EIA Units	1

What you get in the box

1 feedthrough panel
Mounting hardware

A BNC-BNC (f) to (f) Panel is

available for transmitting data signals. It is 44 mm (1.74 in) high with ten floating, isolated connectors.

Specifications – BNC-BNC (f) to (f) Panel

	E3669B
Material	Cold-rolled steel
Weight	.45 kg (1 lb)
Color	Quartz gray
Length	439 mm (19 in)
Height	44 mm (1.74 in)
Width	44 mm (1.74 in)
EIA Units	1
Ground	Outer shield isolated from panel
Nominal impedance	50 Ohms
Voltage rating	500 V RMS
Recommended frequency range	DC to 300 MHz
Contact resistance	Center: 1.5 Milliohm (max) Outer: 0.2 Milliohm (max)
Life	Minimum 10,000 insertion/withdrawal cycles
BNC specifications	Meets MIL-C-39012

Ordering Information

Part No.	Description	Height	EIA units
E3668B	Feedthrough panel with 2 cutout grooves	44 mm (1.74 in)	1
E3669B	BNC-BNC (f) to (f) panel with 10 floating, isolated connectors	44 mm (1.74 in)	1

What you get in the box

BNC panel assembly
Mounting hardware

Small Parts

▶ Rack Filler Panels

Spaces between instruments on the front face of the Agilent rack cabinet can be filled with metal filler panels. Filler panels provide an attractive system and eliminate dust from gathering on equipment.

- Quartz gray
- Each panel is 19 inches wide.
- Includes mounting hardware.

Ordering Information

Part No.	Description	EIA Units
E7731A	1 EIA unit filler panel	1
E7732A	2 EIA unit filler panel	2
E7733A	3 EIA unit filler panel	3
E7734A	4 EIA unit filler panel	4
E7735A	5 EIA unit filler panel	5
E7736A	6 EIA unit filler panel	6
E7737A	7 EIA unit filler panel	7

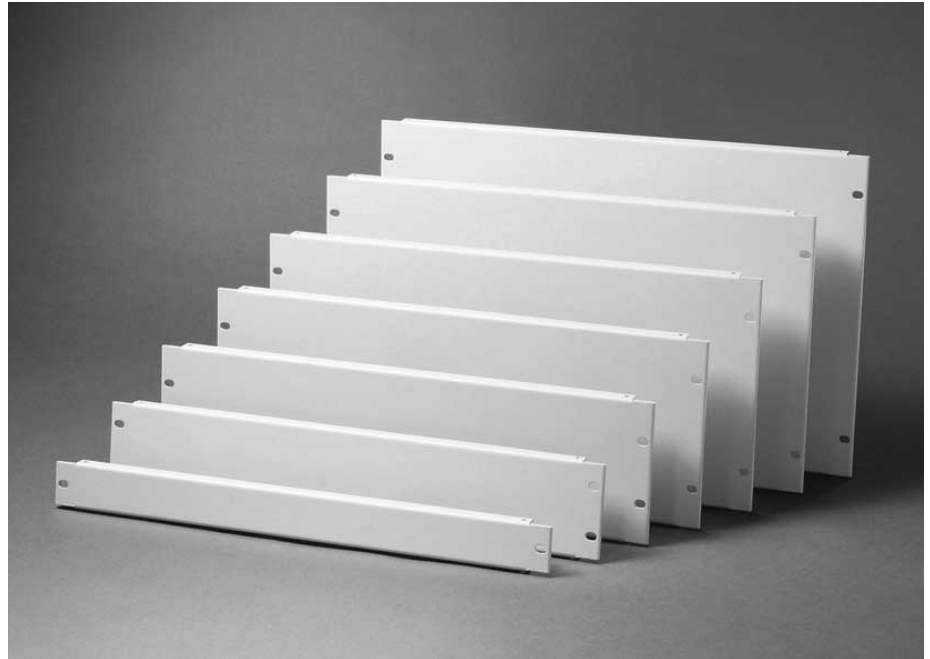

Filler panels, from smallest to largest



IEC-320 female-male power cables (8120-1860)

◀ IEC-320 Female-Male Power Cables

Most Agilent products are shipped with detachable power cords with a localized male plug on one end and an IEC-320 female connector to plug into the instrument. Substitute the regular power cord with one of the following to connect your Agilent instrument/controller to the IEC-320 versions of our PDUs.

Ordering Information

Part No.	Description
8120-1575C	762 mm (30 in) gray power cable
8120-1860	1524 mm (60 in) gray power cable

What you get in the box

1 Power cable

Small Parts

▼ Mounting Hardware

Rackmount kits include all required hardware. Order mounting hardware when additional or replacement hardware is needed. Choose the desired mounting hardware from the list below.

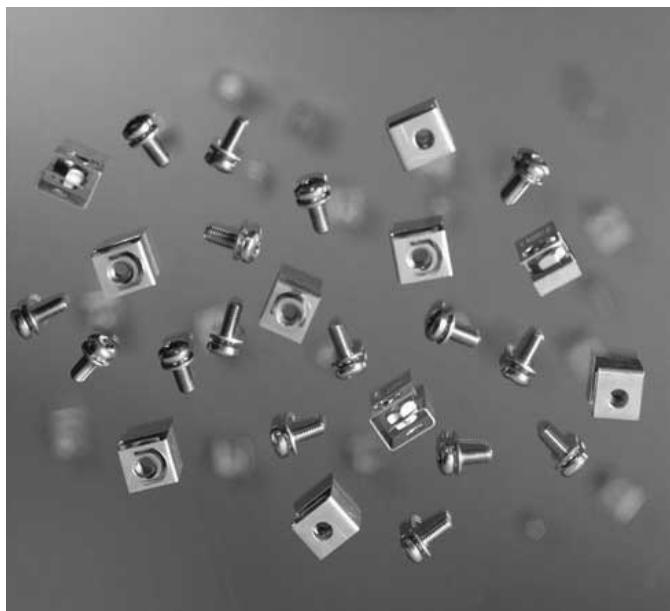

Mounting hardware, non-decorative (E7694A)



Mounting hardware, decorative (E7797A)

Ordering Information

Part No.	Description	Color
E7797A	50 clip-on sheet metal nuts and 50 10-32 decorative screws	Quartz gray
E7694A	50 clip-on sheet metal nuts and 50 10-32 non-decorative screws	Non-decorative
0590-0804	1 clip-on sheet metal nut. Order the desired quantity for your needs.	Non-decorative
0570-1366	1 10-32 screw. Order the desired quantity for your needs.	Parchment white
J1522AC	10 Torx T25 decorative screws (quartz gray), 10 Torx T25 non-decorative screws with lock washers, and 20 U-type sheet metal nuts	Quartz gray and non-decorative

Small Parts

Frequently Ordered Replacement Parts

Rear Door Hinge

Hinges are available for Agilent's rear doors, which come with standard racks and can also be ordered individually.

Ordering Information

Part No.	Description
C2786-00012C	Rear door hinge

What you get in the box

- 1 Hinge
- Mounting hardware

Forehead Bezels

Replacement forehead bezels can be ordered with or without a cutout for a power switch (power switches come with power distribution units).

Ordering Information

Part No.	Description
5061-8749C	Forehead bezel without switch cutout
5061-8750C	Forehead bezel with switch cutout

What you get in the box

- 1 Forehead bezel
- Mounting hardware

Recommended Purchase

Quartz Gray Paint

The quartz gray paint used for all racks and rack accessories is available. Order an aerosol spray can of paint to complete touch-ups and other minor paint repairs.

Ordering Information

Part No.	Description
6010-1522C	1 aerosol spray can quartz gray paint

What you get in the box

- 1 Can spray paint

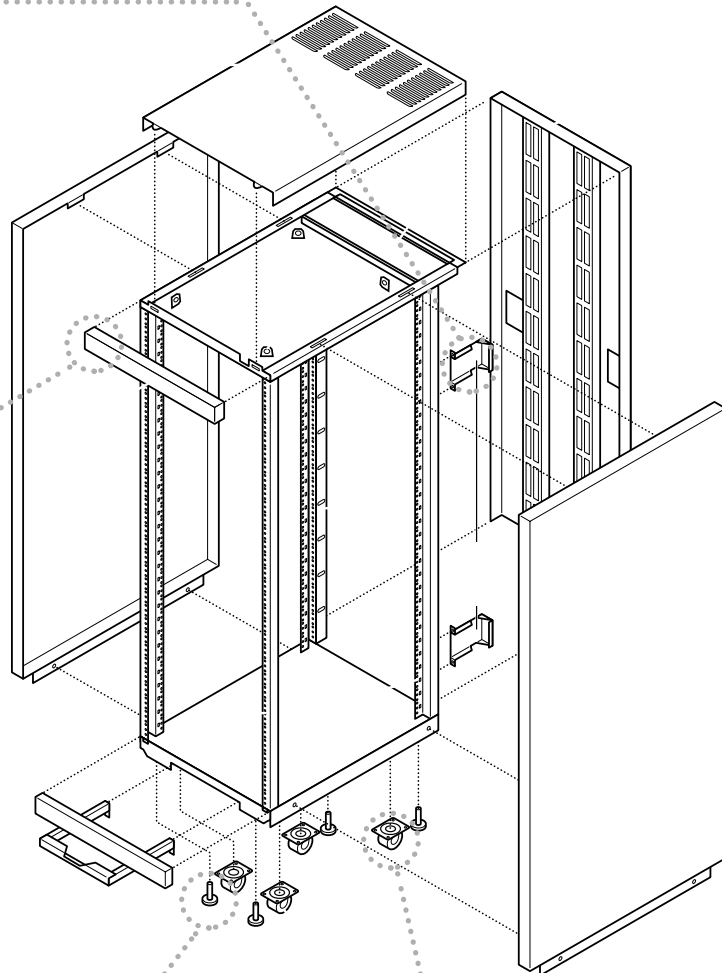

Leveling Screws

Agilent's standard racks come with leveling screws. Replacement screws are available.

Ordering Information

Part No.	Description
0403-0778C	Leveling screws

What you get in the box

- 1 Leveling screw

Caster

Heavy duty 3-inch casters are shipped with all standard Agilent racks. Agilent's casters may also be ordered if a replacement or extra set of casters is needed.

Ordering Information

Part No.	Description
1492-0159C	Castors for standard racks

What you get in the box

- 1 Caster

Agilent Testmobile Carts add protection and mobility to test instruments and systems. The convenience of mobility makes instruments readily available when needed. The cart effectively extends the amount of lab bench space. Ergonomic cart and accessory design makes test equipment accessible to the operator, whether seated or standing at the test area. Additionally, several operators can cost effectively share expensive equipment that has been mounted on a Testmobile Cart.

Competitively priced Agilent testmobile carts are offered in cart capacities to provide optimum instrument test configuration:

- Scope cart, 59 kg (130 lb)
- System cart, 227 kg (500 lb).

A variety of easy-to-mount accessories are available for customized solutions.

Add Mobility to Your Instruments

Agilent Testmobile carts provide convenient mobility of test equipment, PCs, or workstations to make them readily available when needed. This capability effectively extends the amount of lab bench space available. Mar-resistant, heavy-duty 5-inch hard rubber casters make moving instruments easy. All casters swivel, which lets the cart move right up to the workbench.

Bring the Equipment to the Test

Rather than bringing the test to the equipment, Agilent Testmobile carts bring the equipment to the test, to save time and get right to the task.

Testmobile carts provide a convenient way to move everything from a small oscilloscope to a complete test system to the work to be tested.

Share Expensive Instruments

Agilent Testmobile carts allow several operators in a work group to cost-effectively share expensive equipment. In the case of a small test system, all

instruments can be conveniently combined in one place through the sufficient space, load capacity, and rackmount capability of the testmobile system cart.

Protect Your Investment

Unlike general-purpose cart design, Agilent testmobile carts have a nylon strap and steel buckle that secure instruments to the cart, and instrument feet fit securely in slots in both upper tilt tray and lower fixed tray. Expensive instruments are prevented from sliding or tipping off the cart. Locking brakes on rear wheels provide added safety and convenience.

Use Instruments with Ease

The ergonomically designed tilt tray adjusts 30-plus degrees for viewing and using instruments in comfort whether seated or standing. Lifting and carrying heavy instruments is no longer necessary with the mobility provided by Agilent testmobile carts.

Testmobiles and Accessories

Key Features

Agilent's Testmobile Carts offer the following attractive features:

- Ergonomic design. Test equipment is operator-accessible whether seated or standing.
- Heavy-duty casters make moving instruments easy.
- Includes a nylon strap and steel buckles to secure instruments to the cart.
- Tilt tray adjusts 30-plus degrees for viewing comfort.

Enhance Instrument Output

Agilent Testmobile system and instrument carts can be customized with a range of easy-to-mount accessories that enhance instrument input and output:

- Work surface and antistatic mat that provide a secure, static free work area in front of the instrument
- Plotter/printer stand, which can be set up either 305 mm or 381 mm (12 in or 15 in) high, enables hardcopy output on the spot
- Storage drawer (3.5 inch or 5.25 inch) for a convenient place to store probes, cables, and manuals
- Angle rails for supporting rack mounted instruments
- Attractive quartz gray color

Testmobile Cart Selection Criteria

A key criterion for cart selection is instrument depth. For instruments with a depth up to 17 inches, select the Agilent 1180CZ testmobile scope cart. The Agilent 1181BZ testmobile system cart should be used for instruments up to 24 inches. Static drag chain is supplied on the 1181BZ.



Testmobile scope cart (1180CZ)

◀ Testmobile Scope Cart, 1180CZ

The Scope Cart is conveniently shipped virtually assembled, except for its handle and casters.

- Tilt tray load capacity = 29.5 kg (65 lb)
- Total load capacity = 59 kg (130 lb)
- Tilt tray = 457 mm W x 457 mm D (18 in W x 18 in D)

What you get in the box

- Scope cart assembly with tray
- Tubular handle
- 4 Casters
- Mounting hardware
- Torx T25 screwdriver
- Nylon strap with steel buckle

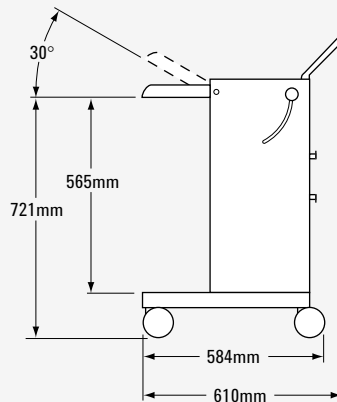

Side View

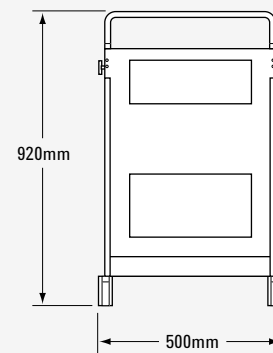

Front View

Testmobiles and Accessories



Testmobile system cart (1181BZ)

◀ Testmobile System Cart, 1181BZ

The System Cart is a small mobile rack that allows for additional equipment to be installed. That cart has space for the rackmounting of any 19" EIA instrument up to 24" deep. The cart is conveniently shipped virtually assembled, except for its handle.

- Tilt tray load capacity = 90.7 kg (200 lb)
- Total load capacity = 226.8 kg (500 lb)

- Tilt tray = 559 mm W x 660 mm D (22 in W x 26 in D)
- Rackmount any 19-inch EIA instrument up to 24 inches deep beneath the tilt tray in EIA columns.
- 12 EIA units available for rackmounting.
- Includes one set of 5957-8476C angle rails to support rackmounted instruments.

What you get in the box

- System cart assembly with tray and casters
- Tubular handle
- One set of support rails
- Mounting hardware
- Torx T25 screwdriver
- Nylon strap with steel buckle

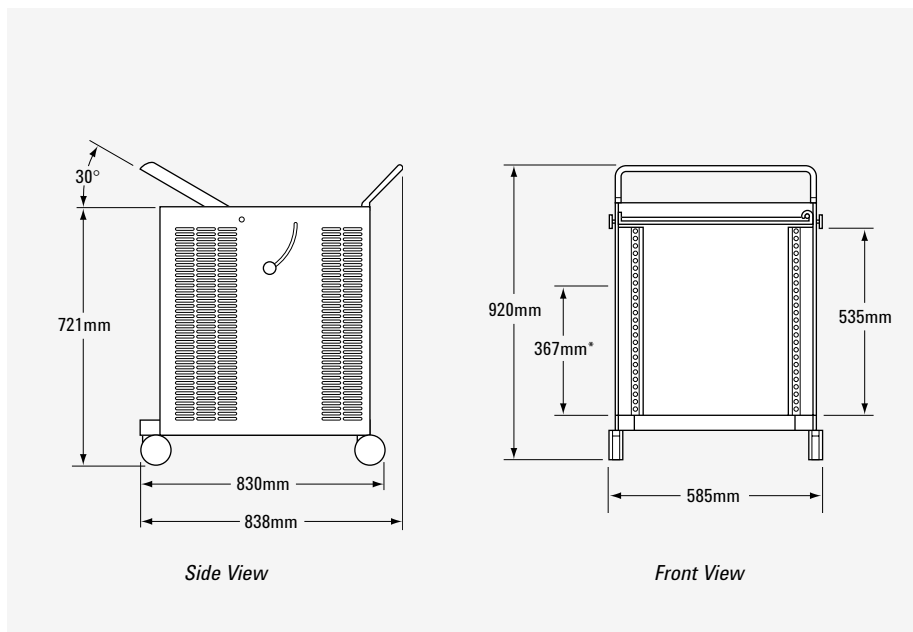

For all Testmobile Carts

Ordering Information

Prod. No.	Description
1180CZ	Scope cart
1181BZ	System cart

Specifications

	1180CZ Scope Cart	1181BZ System Cart
Capabilities		
Tilt tray load	29.5 kg (65 lb)	90.7 kg (200 lb)
Total load	59.0 kg (130 lb)	226.8 kg (500 lb)
Cart net weight	18.1 kg (40 lb)	39.0 kg (86 lb)
Dimensions		
Tilt tray size (w x d)	457 x 457 mm (18 x 18 in)	559 x 660 mm (22 x 26 in)
Height	721 mm (28.4 in)	721 mm (28.4 in)
Width	475 mm (18.7 in)	566 mm (22.3 in)
Depth	508 mm (20.0 in)	737 mm (29.0 in)
Vertical rack space*	n/a	533 mm (21.0 in – 12 EIA units)
Maximum	432 mm (17.0 in)	635 mm (25.0 in)
Instrument Depth		
Casters	101 mm (4 in) diameter	127 mm (5 in) diameter

* Vertical rack space is reduced the more the tilt tray is angled.

Testmobiles and Accessories

Testmobile Accessories Selection Chart

Part No.	Description	1180CZ Scope Cart	1181BZ System Cart
35181HZ	Printer/Plotter stand	n/a	yes
35181KZ	Work surface	n/a	yes
35181J	Storage drawer 3.5" high	n/a	yes
35181M	Storage drawer 5.25" high	n/a	yes
J1520AC	Stationary shelf	n/a	yes
Cables and Plugs			
8120-1575C	IEC-320 cable, 762 mm (30 in.)	yes	yes
8120-1860	IEC-320 cable, 1.5 m (60 in.)	yes	yes
5181-8707	IEC-320male power cable replacement plug	yes	yes
Replacement Parts			
1530-2054C	Tie-down assembly strap (1180CZ)	yes	n/a
1530-2228C	Tie-down assembly strap (1181BZ, 1182B)	yes	n/a

► Testmobile Printer/ Plotter Stand

Conveniently mount a printer or plotter on top of a system or instrument testmobile with the Agilent testmobile printer/plotter stand.

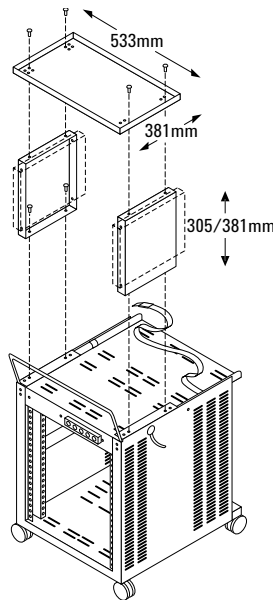

What you get in the box

Printer tray
Vertical side supports
Torx T15 screwdriver

Specifications

	35181HZ
Material	Cold-rolled steel
Weight	8.16 kg (18 lbs)
Color	Quartz gray
Length	533 mm (21 in)
Height	305 mm (12 in) or 381 mm (15 in)
Width	381 mm (15 in)
Load Capacity	11.34 kg (25 lbs)
Compatibility	1181BZ 1182B

Ordering Information

Part No.	Description
35181HZ	Testmobile printer/plotter stand

Testmobiles and Accessories

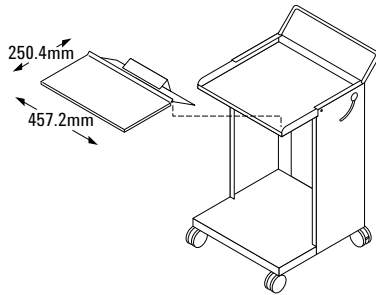

◀ Testmobile Work Surface

Agilent's testmobile work surface provides additional work space on a testmobile cart. It can be used for accessories, writing, or a keyboard and mouse. The work surface attaches to the testmobile tilt tray.

Specifications

	35181KZ
Material	Cold-rolled steel
Weight	4.99 kg (11 lbs)
Color	Quartz gray
Length	533 mm (21 in)
Width	305 mm (12 in)
Compatibility	1181BZ 1182B

What you get in the box

Work surface
Torx T15 screwdriver
Mounting hardware

Ordering Information

Part No.	Description
35181KZ	Work surface for 1181BZ

Testmobiles and Accessories

► Storage Drawer

Agilent's testmobile storage drawer provides storage space for miscellaneous items such as tools, manuals, probes or cables.



Drawer installed in rack

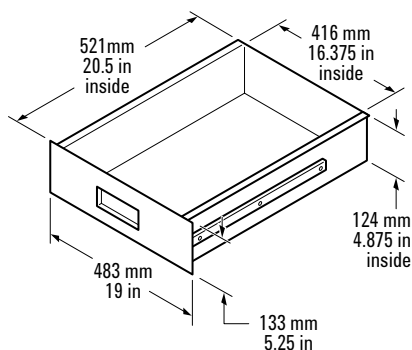

35181M Drawer

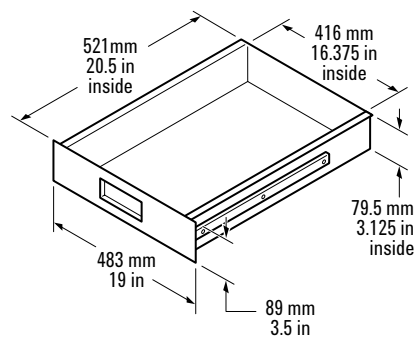

35181J Drawer

What you get in the box

Drawer with slides attached

Mounting hardware

Specifications

	35181J	35181M
Material	Cold-rolled steel	Cold-rolled steel
Weight	7.26 kg (16 lbs)	8.16 kg (18 lbs)
Color	Quartz gray	Quartz gray
Length	521 mm (20.5 in)	521 mm (20.5 in)
Height	89 mm (3.5 in)	133 mm (5.25 in)
Width	483 mm (19 in)	483 mm (19 in)

Ordering Information

Part No.	Description
35181J	3.5" Storage Drawer
35181M	5.25" Storage Drawer



Stationary shelf (J1520AC)

◀ Stationary Shelf

This light-duty fixed shelf is designed to give you a flat surface for placing products in your Agilent testmobile. The shelf is mounted securely into place using the supplied hardware and is designed to sit at the bottom of the EIA increment. The shelf requires 44 mm (1.73 in) of vertical space in the rack.

Attractive features of the stationary shelf include:

- Snap-in design
- Easy installation
- Smooth edges

Specifications

	J1520AC
Material	Cold-rolled steel
Weight	8 kg (17.6 lbs)
Color	Quartz gray
Length	678 mm (26.7 in)
Height	44 mm (1.73 in)
Width	444 mm (17.5 in)
Load Capacity	68 kg (150 lbs)
Compatibility	1181BZ

Ordering Information

Part No.	Description	EIA Units
J1520AC	Stationary shelf	1

What you get in the box

- 1 Stationary shelf
- 2 Rear brackets
- 2 Torx T25 screws with lock washers
- 2 Sheet metal, u-type nuts
- 2 Torx T25 quartz gray decorative screws

Testmobiles and Accessories

IEC-320 Power Cables

Most Agilent products are shipped with detachable power cords with a localized male plug on one end and an IEC-320 female connector to plug into the instrument. Substitute the regular power cord with 8120-1575C or 8120-1860 to connect your Agilent instrument/controller to the IEC-320 versions of our PDUs. We also offer a male power cable conversion plug (5181-8707).

What you get in the box

1 Power cable

Ordering Information

Part No.	Description
8120-1575C	762 mm (30 in) gray female-male power cable
8120-1860	1524 mm (60 in) gray female-male power cable
5181-8707	IEC-320 male power cable replacement plug

www.agilent.com

Agilent Technologies' Test and Measurement Support, Services, and Assistance

Agilent Technologies aims to maximize the value you receive, while minimizing your risk and problems. We strive to ensure that you get the test and measurement capabilities you paid for and obtain the support you need. Our extensive support resources and services can help you choose the right Agilent products for your applications and apply them successfully. Every instrument and system we sell has a global warranty. Support is available for at least five years beyond the production life of the product. Two concepts underlie Agilent's overall support policy: "Our Promise" and "Your Advantage."

Our Promise

Our Promise means your Agilent test and measurement equipment will meet its advertised performance and functionality. When you are choosing new equipment, we will help you with product information, including realistic performance specifications and practical recommendations from experienced test engineers. When you use Agilent equipment, we can verify that it works properly, help with product operation, and provide basic measurement assistance for the use of specified capabilities, at no extra cost upon request. Many self-help tools are available.

Your Advantage

Your Advantage means that Agilent offers a wide range of additional expert test and measurement services, which you can purchase according to your unique technical and business needs. Solve problems efficiently and gain a competitive edge by contracting with us for calibration, extra-cost upgrades, out-of-warranty repairs, and on-site education and training, as well as design, system integration, project management, and other professional engineering services. Experienced Agilent engineers and technicians worldwide can help you maximize your productivity, optimize the return on investment of your Agilent instruments and systems, and obtain dependable measurement accuracy for the life of those products.



Agilent Email Updates

www.agilent.com/find/emailupdates

Get the latest information on the products and applications you select.

By internet, phone, or fax, get assistance with all your test & measurement needs Online assistance:

www.agilent.com/find/assist

Phone or Fax

United States:

(tel) 1 800 829 4444

Canada:

(tel) 1 877 894 4414

(fax) (905) 282 6495

China:

(tel) 800 810 0189

(fax) 800 820 2816

Europe:

(tel) (31 20) 547 2323

(fax) (31 20) 547 2390

Japan:

(tel) (81) 426 56 7832

(fax) (81) 426 56 7840

Korea:

(tel) (82 2) 2004 5004

(fax) (82 2) 2004 5115

Latin America:

(tel) (305) 269 7500

(fax) (305) 269 7599

Taiwan:

(tel) 0800 047 866

(fax) 0800 286 331

Other Asia Pacific Countries:

(tel) (65) 6375 8100

(fax) (65) 6836 0252

(e-mail) tm_asia@agilent.com

Product specifications and descriptions in this document subject to change without notice.

Printed in the U.S.A. February 13, 2004

© Agilent Technologies, Inc. 2004

5980-0450E



Agilent Technologies